

FTM

FABRICATION TOOLS AND MATERIALS



NEW!
Acryl-Cam Lock™
See Page 32

THE FABRICATORS SOURCE®

Ph (530) 626-1986



www.123ftm.com

**COPYRIGHT 2014 FABRICATION TOOLS AND MATERIALS, INC.
ALL RIGHTS RESERVED**

COMPLETE HEATING SYSTEM

For Bending and Forming Plastics



SYSTEM INCLUDES

- 4 Heating Trays
- Control Box
- Fence / Stop
- Frame Kit



Scan QR Code
for More Information

Specifications:

- 120 Volt AC / 60HZ
- 800° Operating Temperature.
- 62" Wide x 54" Deep x 5" High.
- 48" Wide x 48" Deep Working Area.
- 68 / lbs Approximate Assembled Weight.



U.S. Patent No. 5025137

Features:

- Micro Processor Controlled.
- Built in 3 Function Timer.
- Ultra Hi-Temperature Insulation.
- Sealed & TEFLON coated working area.
- Heating Trays have a **1 3/4" center to center** measurement when put side by side.
- Powder coated finish.

Model No.	Description	Price
48-48AEC	1/2" Complete Heating Unit	\$1,692.00
48-48AEC/4	1/4" Complete Heating Unit	\$1,732.00

To Add an Extra Tray or Fence:

FS-48T	1/2" Extra Table Heating Tray	\$276.00
FS-48T/4	1/4" Extra Table Heating Tray	\$290.00
88076	Extra Fence / Stop	\$132.00

Model Usage Guide for Material Thickness:

48-48AEC 1/8" and thicker material
48-48AEC/4 .100" and thinner material

Replacement Trays

TT-48A	1/2" Table Tray (AEC)	\$276.00
TT-48A/4	1/4" Table Tray (AEC)	\$290.00

This System prepares thermoplastic materials for forming all-angle bends, and **REDUCES FABRICATION TIME** both in setup and multiple bend operations. Unit has independently operated and movable heating trays, index rules on either side of table, full usage of working area allows you to work from both sides of the table at the same time. The adjustable fence may be positioned anywhere within the frame. Units are completely self-contained and requires **NO SPECIAL WIRING.** (120 volt 15 amps)

FREE-STANDING HEATERS

U.S. Patent No. 5025137

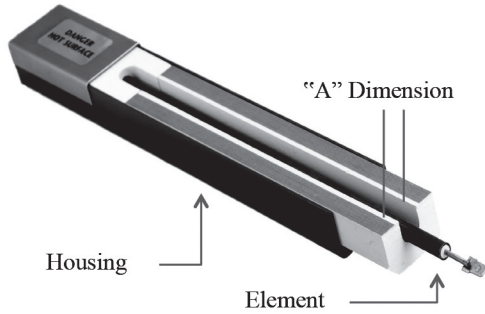
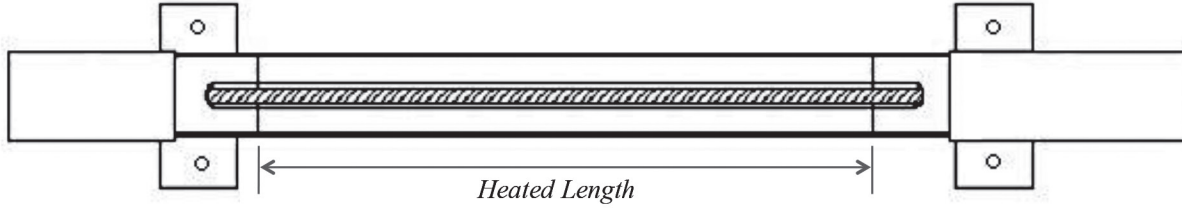

Our Heating Trays have been exclusively designed to give constant professional bends while working with all types of thermoplastic materials, Acrylic, PVC, CPVC, Polypropylene, Polycarbonate, and more. These heaters are ideal for straight line bends or folds and capable of heating material up to 1/2" thick.



- Maximum operating temperature of 800°f.
- Free standing heaters can be used with the AEC15 power control (see page 3).
- Powder coated steel tray and PTFE working surface.

Scan QR Code for More Information

SPECIFICATIONS:

Model No.	Heated Length	"A" Dimension	Housing Length	Watts/Amp	Volts	Price
FS-24	24"	1/2"	35"	220/1.8	120	\$209.00
FS-48	48"	1/2"	59"	430/3.6	120	\$276.00
FS-48/240	48"	1/2"	59"	430/1.8	240	\$276.00
FS-48/4	48"	1/4"	59"	330/2.75	120	\$290.00
FS-3/48	48"	2x1/2" / Custom	59"	860/7.2	120	\$470.00
FS-3/48/4	48"	2x1/4" / Custom	59"	660/5.5	120	\$517.00
FS-48W1*	48"	1"	59"	860/7.2	120	\$449.00
FS-48W2	48"	2"	59"	860/7.2	120	\$473.00
FS-72	72"	1/2"	83"	525/4.4	120	\$410.00
FS-96	96"	1/2"	107"	880/7.4	120	\$445.00

* New for 2014, Free Standing Heater with 1" heated width.

1" & 2" WIDE X 48" FREE-STANDING HEATERS

Model No. FS-48W1 and FS-48W2

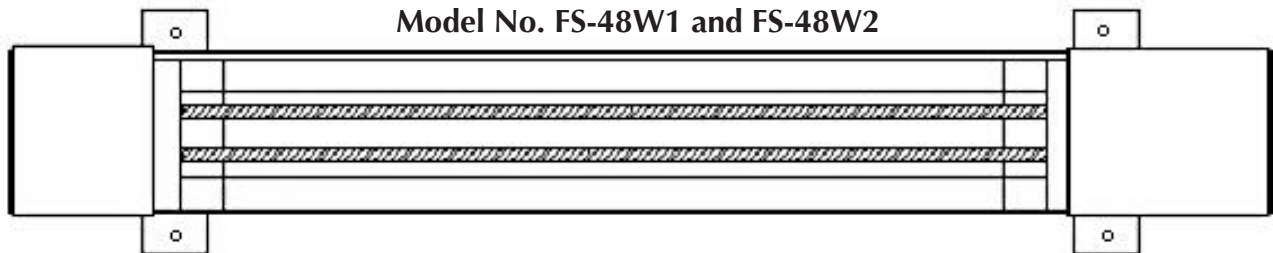

- FS-48W2 Ideal for material up to 1/2" thick, or thinner material requiring a wide radius.
- Use with AEC15 Power Control to tailor the working temperature to your exact needs.

120 VOLT POWER CONTROLLERS

AEC120

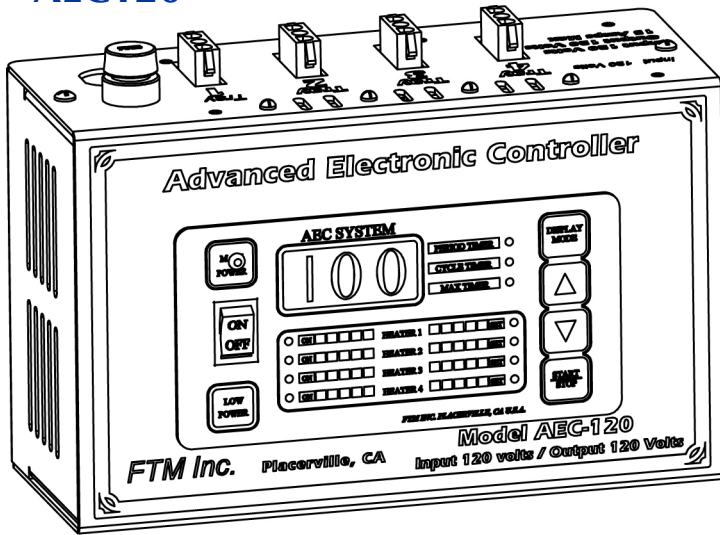

This **120 Volt** Stand Alone **Advanced Electronic Controller (AEC)** is our 4th generation Power Control. We feel it's the **MOST ADVANCED** in the industry.

AEC SYSTEM FEATURES:

- Micro Processor.
- Custom Software.
- Custom Designed Solid State Circuit Board.
- Large Digital Readout Display.
- Touch Pad Controls.
- Built-in 3 Function Timer.
- Low Voltage Warning.
- Main ON / OFF switch.
- Individual Indicator Light for each tray.
- Each Heating Tray is individually controlled.
- Each Tray can be unplugged from AEC.
- 4 Channel (each at 3.5 amps max)
- Controller requires 4 tray cords #3205.
(Sold Separately)

Model No.	Voltage	Price
AEC120	120	\$404.00

Extra Tray Cords

3205	Tray Cord	\$8.00 each
------	-----------	-------------

AEC15 Controller

This rugged controller is FTM's **3rd Generation** power control. The AEC15 was built from the ground up using the same sophisticated Advanced Electronic Controller (**AEC**) technology we use in our AEC120 controller. Using a Digital Micro Processor allows the AEC15 to have **OVERLOAD PROTECTION**. If the controller senses an amperage overload, it will automatically limit the current flow to 15 amps and warn the operator with an indicator light. The controller also has a **LOW VOLTAGE** indicator light that warns you if your supply voltage drops below 100 volts. The power control has a rugged **ANODIZED ALUMINUM HOUSING** with an internal **COOLING FAN!** This advanced technology, designed for FTM's equipment, is now user friendly with **NiChrome wire**.

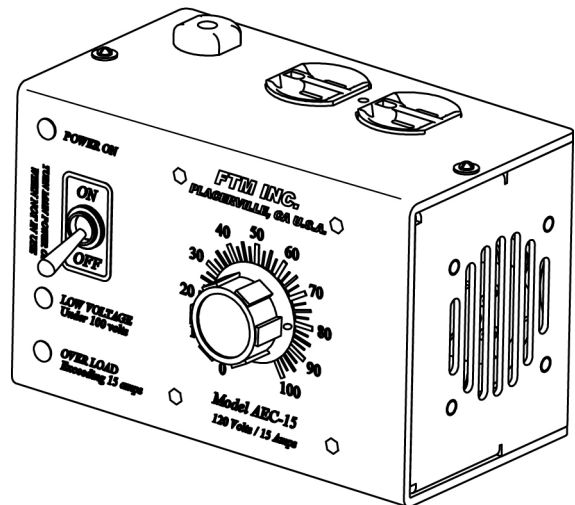

Model No.	Voltage	Price
AEC15	120	\$235.00

SILICONE HEATERS

Our **WIDE HEAT** Silicone Heaters now give you the ability to heat thermoplastic material up to **6" WIDE**. Ideal for material up to **1½" thick**, or thin material requiring a wide radius. Also ideal for heating rod or tube material, as flexibility of heater will allow you to bend or wrap it to fit. Can be used with our **power control**, which allows you to tailor the working temperature to your exact needs.

Specifications: All Heaters are 120 Volts, 60hz

Part No.	Heated Area	Amps / Watts	Maximum Temperature	Price	
4101	1" x 29"	1.20/145	All stock heaters are 5 watts per sq. inch and heat to a maximum surface temperature of 475°f. CUSTOM sizes and watt densities are available upon request and have approximately a 4-5 week lead time from time of order.	\$69.75	
4102	2" x 29"	2.42/290		\$95.55	
4103	4" x 29"	4.83/580		\$120.45	
4104	6" x 29"	7.25/870		\$169.00	
4201	1" x 41"	1.71/205		\$80.45	
4202	2" x 41"	3.42/410		\$114.10	
4251	1" x 53"	2.17/265		\$83.55	
4252	2" x 53"	4.41/530		\$148.30	
4253	4" x 53"	8.83/1,060		\$205.35	
4254	6" x 53"	13.25/1,590		\$289.25	
4301	1" x 101"	4.20/505		\$133.30	
4305	1" x 125"	5.2/625		\$166.25	
Note: This Heater has 2 cords - One at each end.					
3003	¾" x 6" x 12" Insulation for under heaters			\$25.00	

REPLACEMENT PARTS FOR HEATERS & OTHER USES

Part No.	Description	Replacement For	Price Each
SK1	Sealer Kit	For all Heating Trays	\$39.00
4008	Insulation, 1/2" x 48"	1/2" Heating Trays	\$68.00
4005	Insulation, 1/4" x 48"	1/4" Heating Trays	\$68.00
25000	Left / Right RULES	Complete Heating Systems / Table Saws	\$19.50
3291	J Bolt Clamp Set	Fence/Stop	\$13.00
9958	Element Only 120 Volts	Free Standing Heater FS-72	\$79.00
11006	Element Only 120 Volts	Free Standing Heater FS-96	\$98.00
11007	Element Only 120 Volts	Free Standing Heater FS-48	\$65.00
11008	Element Only 120 Volts	Free Standing Heater FS-24	\$41.25
11009	Element Only 120 Volts	Free Standing Heater FS-48/4	\$95.00

VACUUM / CLAMPING - SYSTEM

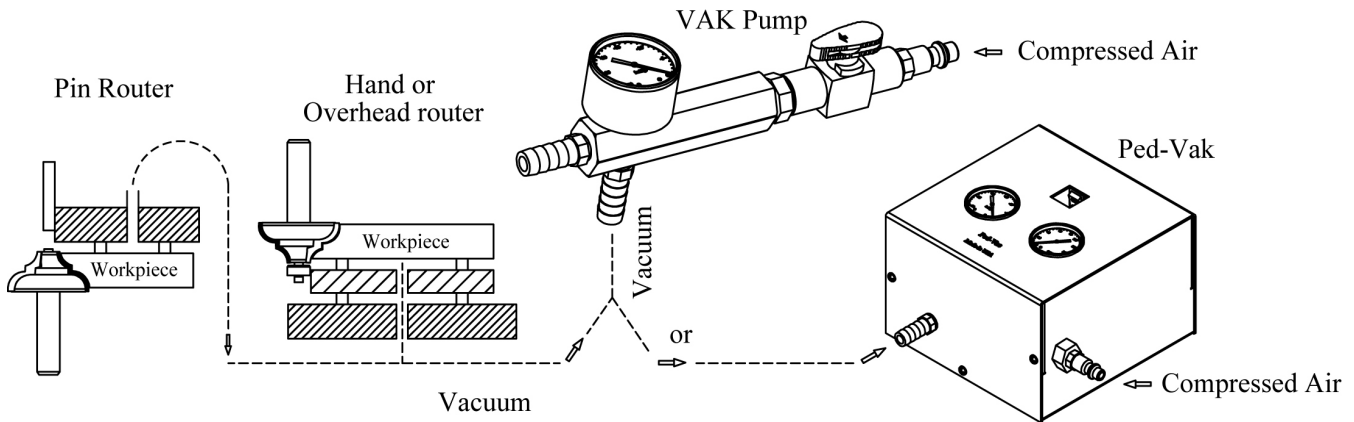

Strong clamping with over **1800 pounds/sq.ft** of force to hold work pieces for sawing, sanding, forming, and all **Routing** functions. No mechanical clamps to get in the way. **Heavy Duty system creates more holding force on porous materials and evacuates at twice the speed of the standard system.**

Part No.	Description	SCFM/PSI	VAC/SCFM	Price
VP4	Standard Vacuum Kit	4/85	3.2	\$145.00
VP6	SuperPro Vacuum Kit	6.5/85	5.2	\$190.00
VP10	Industrial Vacuum Kit	13/85	10	\$285.00
PV4	Standard Pedal Vacuum Kit	4/85	3.2	\$275.00
PV6	SuperPro Pedal Vacuum Kit	6.8/85	5.2	\$315.00
QD1	Pack of 5 Connectors			\$16.00

Part No.	VACUUM TAPE	EACH	6	12
VT50	1/4" Wide x 50' Vac Tape	\$6.95	\$6.15	\$5.00

SAW-LECTOR GUIDE FOR BLADES ON PAGE 6

Maximum Thickness to Cut

Material to be Cut	1/16"	1/8"	1/4"	1/2"	1"	2"
Acrylic, Cell & Continuous Cast	TR	TR / TL		PLG	PLH	
Acrylic, Extruded	TRL	TRL / TLL		TLL	PLL	
Polycarbonate / PETG / Styrene	PLGX			PLGN		
Nylon / Polypropylene / Teflon	PLN					
Polyethylene / PVC / ABS	TLL		PLG			
Polyurethane Durometer 85 or Denser	PLU					
FoamBoard / Paper Surfaced (Fome-Cor®)	PLF-TR					
FoamBoard / Plastic Surfaced (GatorPlas®)	GATR					
Phenolic	PHN					
UHMW	TLL			PLL		
Rigid Vinyl	PLGN					
Sintra	PLG					
Fiberglass / G10	R805					
Woods	HP					

SAW BLADES FOR PLASTICS

Part No.	Dia.	Teeth	Kerf	Bore	Price
----------	------	-------	------	------	-------

TR Series - Thin Rim / Cast

TR087203	8"	72	.075"	5/8"	\$191.65
TR108003	10"	80	.080"	5/8"	\$199.50

TL Series - Thin Line / Cast

TL087204	8"	72	.080"	5/8"	\$154.50
TL108004	10"	80	.085"	5/8"	\$169.00

PLG Series - General Purpose

PLG08603	8"	60	.100"	5/8"	\$113.50
PLG10723	10"	72	.115"	5/8"	\$128.75
PLG10803	10"	80	.115"	5/8"	\$140.75
PLG12803	12"	80	.125"	1"	\$151.75
PLG14803	14"	80	.145"	1"	\$157.75

TRL Series - Thin Rim / Extruded

TRL10804	10"	80	.095"	5/8"	\$216.00
TRL12904	12"	90	.105"	1"	\$245.00
TRL14904	14"	90	.105"	1"	\$262.00

TLL Series - Thin Line / Extruded

TLL08724	8"	72	.105"	5/8"	\$152.25
TLL10804	10"	80	.105"	5/8"	\$174.75
TLL12804	12"	80	.105"	1"	\$192.00
TLL121004	12"	100	.105"	1"	\$214.00
TLL141004	14"	100	.125"	1"	\$280.00

PLL Series / Extruded

PLL10724	10"	72	.135"	5/8"	\$157.00
PLL109004	10"	90	.120"	5/8"	\$184.25
PLL12804	12"	80	.155"	1"	\$184.25
PLL16804	16"	80	.165"	1"	\$215.00

Part No.	Dia.	Teeth	Kerf	Bore	Price
----------	------	-------	------	------	-------

POLYURETHANE Durometer 85 or Denser

PLU1024	10"	24	.103"	5/8"	\$123.75
---------	-----	----	-------	------	----------

PLH Heavy Duty Series / CAST

PLH10603	10"	60	.135"	5/8"	\$120.25
PLH12603	12"	60	.145"	1"	\$128.75
PLH16723	16"	72	.170"	1"	\$172.25

PLGN Series - Polycarbonate / Styrene

PLGN10904	10"	90	.110"	5/8"	\$184.00
-----------	-----	----	-------	------	----------

PLGX Series - PETG / Polycarbonate

PLGX10904	10"	90	.110"	5/8"	\$172.25
PLGX121004	12"	100	.115"	1"	\$185.50

PLN Series / Nylon - Polypropylene

PLN08247	8"	24	.135"	5/8"	\$89.50
PLN10247	10"	24	.135"	5/8"	\$110.00
PLN12307	12"	30	.135"	1"	\$130.00
PLN14367	14"	36	.149"	1"	\$145.75

Foam Core Cutting Blades

PLF-08802AF	8"	80	.065"	5/8"	\$189.00
PLF-101002AF	10"	100	.093"	5/8"	\$224.00
GATR-101003	10"	100	.093"	5/8"	\$199.00

PHENOLICS

PHN0848BAT	8"	48	.125"	5/8"	\$143.25
PHN1048BAT	10"	48	.135"	5/8"	\$145.75
PHN1248BAT	12"	48	.145"	1"	\$154.50

CUSTOM BLADES AVAILABLE

TENRYU SAW BLADES

Part No.	Dia.	Application	Teeth	Kerf	Bore	Price
----------	------	-------------	-------	------	------	-------

PLASTIC CUTTER SERIES

Designed for general purpose cutting applications, the Plastic Cutter blades will perform very well in a wide variety of plastic materials.

PC-25580CB	10"	For cutting a variety of plastics on 10" saws.	80	.102"	5/8"	\$85.00
PC-305100CB	12"	Fine cutting blade for working with plastics.	100	.110"	1"	\$115.00

PRO SERIES FOR PLASTICS

Laser cut, press-tempered, individually tensioned, and chrome-plated bodies bring the cutting edge to the workpiece with unparalleled precision. Each blade features high-grade, fine-grain C4, wear-resistant carbide tips for long life.

PRP-25580CB	10"	Exceptional cuts in standard stock.	80	.125"	5/8"	\$150.00
PRP-305100CB	12"	Superior plastic cutting blade, none better.	100	.134"	1"	\$190.00
PRP-355100CB	14"	Great for a variety of plastic materials.	100	.134"	1"	\$216.00

OPTIMIZE YOUR CUTTING PLANS

Other programs cost more, the ITEMIZER does more...

- Efficient Cutting Plans in Minutes
- Prevent Costly Cutting Errors
- Smart Drag and Drop
- Diagrams for Cutting

7605	Mini-Mizer	\$79.00
7603	Itemizer	\$169.00

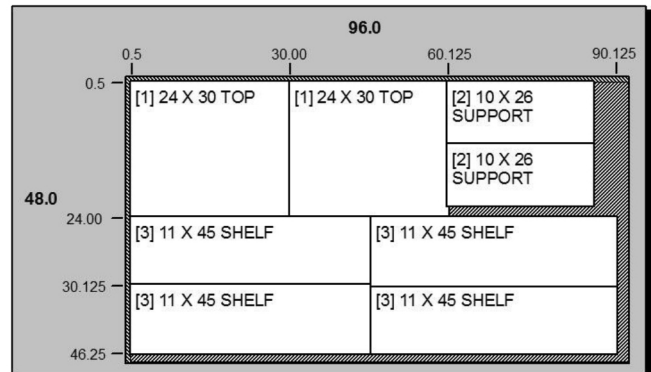

The Itemizer computer software develops optimized cutting plans using dedicated routines for panel, roll, and linear stock. It is used by all industries that require optimization for their cutting processes.

A user defined default start-up file eliminates common or repetitive entries and power search routines boost efficiency by analyzing multitudes of cutting schemes. The part bin feature provides a means to rearrange, reorient and relocate pieces. You can turn pieces vertically or horizontally and move pieces between layouts. You have complete control to tweak the cutting plans after they are automatically generated. Smart Drag and Drop warns you if a piece doesn't fit in its new location or if sheet cutting quantities are affected.

Multi-view shows all or any portion of your layouts on one screen and can be printed accordingly, reducing the amount of drawings required for the shop. Grain can be set for individual items and grain indicator lines can be displayed. User selected descriptions can be printed on the drawing and sheet stock pick lists can be employed to speed stock entry.

The program figures cost, prints custom labels, selects optimum sheet size, works in English or metric units, exports DXF and coordinate files for CAD and CNC purposes and more.

VERTICAL PANEL SAWS



Safety Speed Manufacturing!
Made in USA

- 1 Person Operation
- Dust Ports
- Industrial-Duty Motors
- Material Rollers
- Built-in Rulers
- Rugged Construction
- Low Maintenance Bearing & Guide

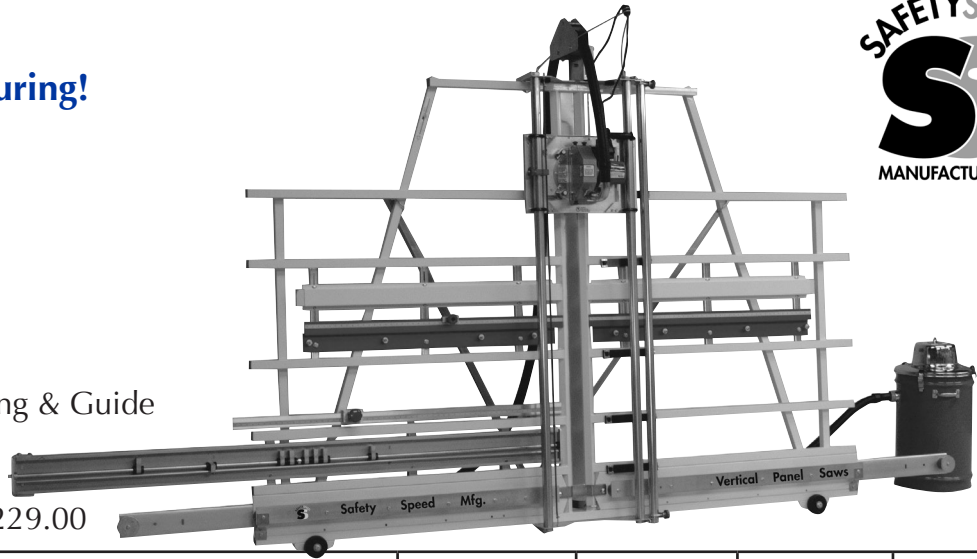

FOB: MN

*Shipping rates as low as \$229.00

Models	Description	Saw Motor	Cross Cut	Accuracy	Price**
H4	The H Series offers full-size vertical panel saw productivity in economical machines. Cut within 1/32" on a wide variety of material up to 1-3/4" thick. / Milwaukee Motor	3-1/4Hp	50"	1/32"	\$2,029.00
H5		3-1/4Hp	64"	1/32"	\$2,159.00
H6		3-1/4Hp	74"	1/32"	\$2,429.00
6400	Heavy-duty worm gear saw motor and additional steel supports in frame for production applications. / Skil Motor	3Hp Worm Drive	64"	1/64"	\$3,589.00
6800		3Hp Worm Drive	74"	1/64"	\$4,099.00
7400	Continuous production and tight tolerance cutting. The 7400XL offers an extra long 13' frame. / Baldor Motor	3Hp / 3phase	64"	.005"	\$9,409.00
7400XL		3Hp / 3phase	64"	.005"	\$10,169.00
SR5U	Saw/Router with heavy-duty 3Hp saw motor, and 3-1/4Hp router where both panel sizing and routing are required. / Skil Motor - Portor Cable Router	3Hp Worm Drive	62"	1/64"	\$5,309.00

**Cash Price Discount

Option Packages		
<p>Bronze Package \$399.00 QUICK STOP™ Gauge 5 ft. Saw blade for general purpose Fixed/folding stand with C-Series Wheels Save over \$110</p>	<p>Silver Package \$599.00 QUICK STOP™ Gauge 8 ft. Dust collection kit Saw blade for fine wood Fixed/folding stand with C-Series Wheels Save over \$190</p>	<p>Gold Package \$799.00 MID-WAY FENCE™ QUICK-STOP™ GAUGE 8 ft. Saw blade for melamine, veneer, and laminates Fixed/folding stand with C-Series Wheels Save over \$280</p>

* Shipping rates as low as \$229.00 for "H" Series in continental USA.
Non commercial and lift gates at additional cost.

LEISTER HOT AIR TOOLS

TRIAC AT



Features:

- Rugged design suitable for the work site
- Adjustable digital temperature control setting
- Adjustable air volume setting
- Digital «e-Drive» display
- Ergonomic handling
- Dual Air Filters

The new **Triac AT** is ideal for plastic welding. It allows you to control your temperature and airflow separately. These two parameters are critical for many plastic welding

applications. Temperature settings and airflow settings are easily viewed and adjusted using the new e-drive display. The **Triac AT** incorporates a temperature probe that guarantees a precise temperature. Dual air filters are easily removed for cleaning. The **Triac AT** features a protective heater tube for user safety. The Leister **Triac AT** has been designed with you the plastic welding professional in mind .

Model 141.316	Triac AT	120 V/1600W	\$499.00
---------------	----------	-------------	----------

Features:

- Adaptor tube with heat protection
- Electronic heating element protection
- Motor shut-off at minimal carbon level
- Suitable for continuous operation



TRIAC S

Leister's **Triac S** has the worldwide reputation of a workhorse. The **Triac S** is an economical and extremely rugged tool designed with dependability and long life in mind. Simply plug in the tool and turn it on; select your temperature and you are ready to go. The tool is self-contained; there is no need for additional compressors or hoses.

Model 100.726	Triac 'S' Hot Air Welder	120V/1600W	\$460.00
Model 100.705	Triac 'S' Hot Air Welder	230V/1600W	\$499.00

Nozzles:



\$51.00	\$50.00	\$50.00	\$50.00	\$50.00	\$50.00	\$50.00
100.303 5mm Tubular Nozzle	106.989 3mm (1/8") Speed Nozzle	106.990 4mm (5/32") Speed Nozzle	106.991 5mm (3/16") Speed Nozzle	106.992 5.7mm (triangular) Speed Nozzle	106.993 7mm (triangular) Speed Nozzle	106.996 Tacking Jet

LEISTER HOT AIR TOOLS

DIODE S



Features:

- Electronic temperature control
- Overheating protection for elements
- Heat protection sheath covers the barrel of the tool
- Push fit nozzles for a wide variety of welding rod sizes
- Air supply provided by optional Minor Blower or Robust Blower (can also be used with regulated shop air)

The Leister **Diode S** is our most popular “PEN” style plastic welding tool. The **Diode S** is easy to handle and lightweight. This tool is ideal for working in tight areas. Step-less electronic temperature control allows the user to weld all types of plastic easily. The **Diode S** combined with the Minor blower makes this a truly portable welder.

Model 101.291	Diode ‘S’ Hot Air Welder	120V/1600W	\$521.00
Model 101.281	Diode ‘S’ Hot Air Welder	230V/1600W	\$516.00
Model 101.447	Diode ‘S’ with Minor	120V/1700W	\$912.00
Model 101.441	Diode ‘S’ with Minor	230V/1700W	\$902.00



Minor Blower Features:

- Airflow: 400 liters/min – 14 CFM
- Weighs 1.15 kg – 2.53 pounds
- W/3 meter cord

Minor Blower (pictured with Diode S) The Minor Blower is small but mighty. This very powerful blower can provide ample airflow for the Diode. The Minor Blower combined with Leister welders provides a portable air supply.

Plastic Welding Rod

Material	5 lb. Coil	10 lb. Coil	30 lb. Spool
HDPE Natural	\$45.00	\$90.00	\$219.00
HDPE Black	\$47.50	\$95.00	\$234.00
PP Natural	\$45.00	\$90.00	\$216.00
PP Black	\$47.50	\$95.00	\$237.00
PP White	\$47.00	\$94.00	\$237.00
PVC Type 1 White	\$47.50	\$95.00	\$237.00
PVC Type 1 Gray	\$47.50	\$95.00	\$237.00

AS-SP Starter Package Of Welding Rod	\$28.00 For 3 lbs.	Includes: One pound HDPE Black 4mm / 5/32” welding rod One pound PP Natural 4mm / 5/32” welding rod One pound PVC White 4mm / 5/32” welding rod
--------------------------------------	--------------------	--

*Minimum order 5 lbs. Please note all prices subject to change without notice.

FLAME POLISHING EQUIPMENT

Part No.	Description	Price
----------	-------------	-------

TORCH KITS & ACCESSORIES

23-1001	Torch Kit : Includes Torch, Size 3 -7 curved tips, 8' hoses and complete instructions.	\$151.65
14014	Stand / Base	\$31.50
7348	Packing, Replacement for Torch	\$7.00
7345	Valve Complete - Green	\$20.75
7346	Valve Complete - Red	\$20.75

REGULATORS / Single Stage ½ Lb DK Rise 1 PSI Increment gauge - Designed for Small Torch

208	Oxygen, Single Stage	\$147.80
406	Hydrogen, Single Stage	\$147.80

MANIFOLDS connect 2 hoses to same regulator

NE135	2 Hose Manifold, Oxygen	\$45.00
NE136	2 Hose Manifold, Fuel	\$45.00

HOSES

4-8	8' Dual Hose System - Fuel & Oxygen	\$49.90
3-8	8' Hose, Fuel	\$24.95
1-8	8' Hose, Oxygen	\$24.95

TIPS

1401	Replacement Tips 1-7	Price Each	\$21.55
------	----------------------	------------	---------

SAFETY ITEMS

N113	Spark Igniter	\$3.95
H753	Flash Back Arrestors / Set	\$55.00

Recommended Gas Pressure Setting (PSI) for 23-1001 Torch Tips

Tip Size	Oxygen	Fuel
1	2	2
2	2	2
3	4	4
4	4	4
5	6	6
6	6	6
7	8	8

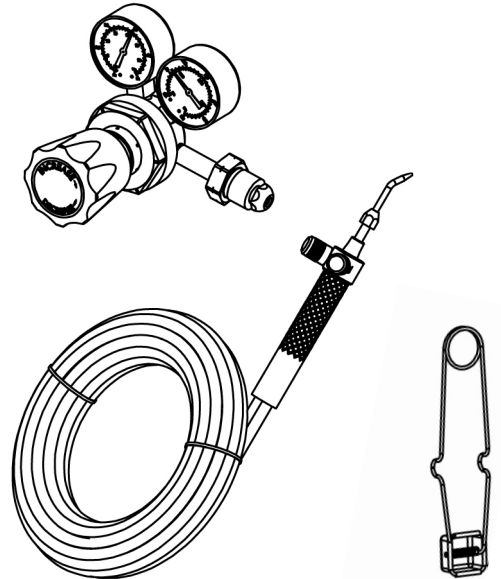

2" ABRASIVE FLAPWHEELS

Part No.	Description	Each	10	20
613/80	80 Grit 2" Wheel	\$10.90	\$9.35	\$8.75
613/180	180 Grit 2" Wheel			
613/240	240 Grit 2" Wheel			

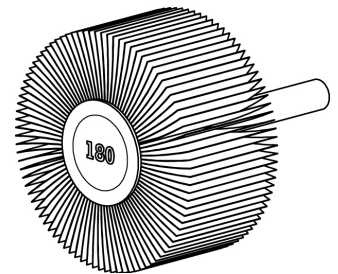

Ideal for finishing edges on all types of plastics, especially radius and holes that are normally hard to finish. The small abrasive flapwheel consists of resin-bonded aluminum oxide abrasive cloth flaps attached to a spindle-mounted core. These flapwheels are used on portable / hand held power tools to **sand, debur, or finish** small or hard-to-handle parts. Suitable on plastics, metal, and wood.

SCRAPERS

FOR THE PLASTIC FABRICATOR. These custom scrapers are not only ideal for scraping flat surfaces, but can also be used to bevel and radius edges. These quick and handy tools make it easy to debur holes and curves of any size. **The Acryl-Scraper™** with **CERAMIC BLADE** is the ultimate in blades for scraping. They have an **unsurpassed flatness** and **square edge**. Once you have used one you will be sold for life.

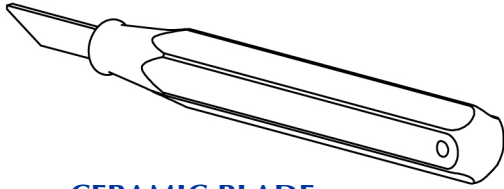

CERAMIC BLADE
#CS100

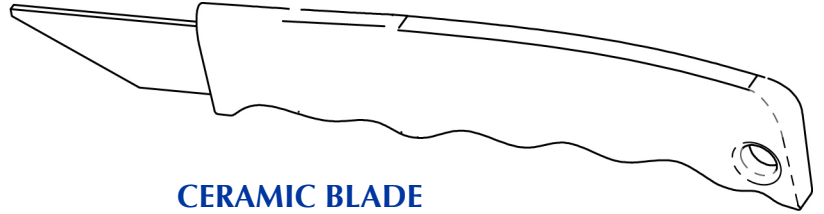

CERAMIC BLADE
#CS200

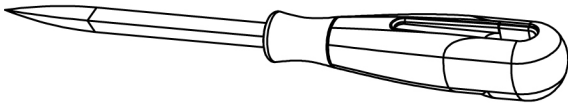

Metal Scraper #5360



Scribe #5370

Part No.	Description	Each	2	6
CS200	Acryl Scraper - Large	\$25.65	\$22.75	\$21.25
CS100	Acryl Scraper - Small	\$25.65	\$22.75	\$21.25
5360	Metal Scraper	\$2.75	\$2.65	\$2.50
5370	Scribe	\$2.70	\$2.50	\$1.95

#TS150 NEW Tandem Edge Scraper \$27.95

- Saves time which reduces labor costs
- Scrape up to 1½" thick edges
- Works on 90° and angled edges
- Replaceable twin scraping blades
- Tough powder coated steel design
- Made in the USA

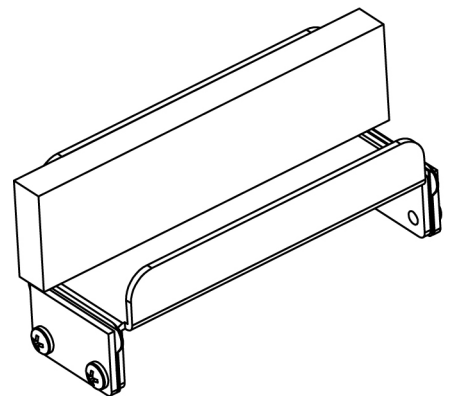

DRILL SETS FOR PLASTICS

Black and Gold Series; Special Hi-Molybdenum tool steel, gold surface treated body, flute and point for maximum lubricity. Super CHIPFREE™ point is precision ground at a 60 degree angle for gradual penetration to avoid cracking and chipping of the acrylic material. 1/8" - 1/4" drills have a straight shank, 5/16" - 1/2" drills have a 1/4" reduced shank. High quality soft case securely holds and protects drills. Case has hook and loop closure and a convenient belt clip.

1/4" Reduced Shank



Part No.			
BG4500	7PC Set	1/8" to 1/2" 1/8" increments	\$49.37

Acryl-Point™ drills are designed to cut acrylics. Included angles and the cutting angles are reduced to keep the drill from biting into the acrylic too fast. 80 degree point produces a clean hole and prevents the drill from breaking the acrylic when drilling through the backside.

Acryl-Point™ Drills



Part No.			
31700	7PC Set	1/8" to 1/2" in 1/16" increments	\$62.35
31725	15PC Set	1/16" to 1/2" in 1/32" increments	\$126.45
31750	29PC Set	1/16" to 1/2" in 1/64" increments	\$236.00

Large Size Drill Sets! Large size and complete sets offer sizes up to 1". Drill sizes from 1/16" to 1/2" are straight shank, and drill sizes from 9/16" to 1" have a 1/2" shank. These sets include Acryl-Point™ drills in a Huot metal drill index. Drill set 31800 comes in one case, drill set 31900 comes in two cases.

Large Drills



Part No.			
31800	8PC Set	9/16" to 1" in 1/16" increments	\$329.15
31900	37PC Set	1/16" to 1" in 1/64" increments, Complete Set!	\$550.40

Specialty Sizes! Numbered, lettered, & metric sets include Acryl-Point™ drills in a Huot metal drill index. All drills are straight shank. Adding a numbered, lettered, & metric set to your shop will allow you to meet the high tolerance needs of your customers!

Specialty Sizes

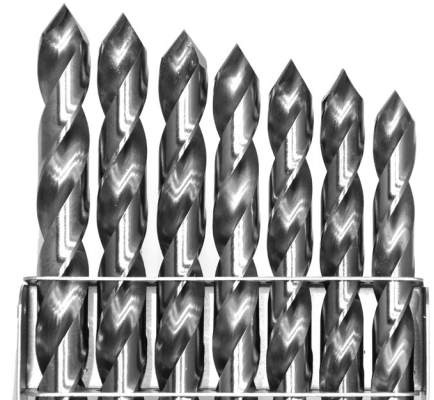

Part No.			
32000	12PC Set	2mm to 13mm Whole #	\$124.15
33000	23PC Set	2mm to 13mm in 1/2 mm increments	\$230.25
34000	26PC Set	A to Z lettered Complete Set!	\$248.55
35000	52PC Set	1 to 52 Numbered Complete Set!	\$243.15

INDIVIDUAL DRILLS

INDUSTRIAL QUALITY HSS DRILLS

BLACK & GOLD SERIES

Special Hi-Molybdenum tool steel, gold surface treated body, flute and point for maximum lubricity. Super **CHIPFREE™** point is precision ground. **Avoid cracking and chipping in acrylic material.**

- Specifically for acrylics
- Tool Steel
- 60 degree tip angle
- Eliminates grabbing on break-through

Part No.	Drill Size	Price
BG125	1/8"	\$2.54
BG187	3/16"	\$3.26
BG250	1/4"	\$4.30
BG312	*5/16"	\$6.06
BG375	*3/8"	\$8.33
BG437	*7/16"	\$9.31
BG500	*1/2"	\$11.05

* 1/4" Reduced Shank Drills

General Drill Speeds

Diameter	Speed - RPM
.125"	3000 - 4500
.187"	1500 - 4500
.250"	1800 - 2000
.375"	1500 - 2000
.500"	800 - 1000
Feed Rate of .015"- .020" per Revolution	

ACRYL-POINT™ DRILLS

Part No.	Drill Size	Price
PD062	1/16"	\$3.49
PD078	5/64"	\$3.88
PD093	3/32"	\$3.88
PD109	7/64"	\$3.68
PD125	1/8"	\$3.73
PD140	9/64"	\$4.35
PD156	5/32"	\$4.39
PD171	11/64"	\$4.86
PD187	3/16"	\$4.55
PD203	13/64"	\$5.27
PD218	7/32"	\$5.72
PD234	15/64"	\$5.98
PD250	1/4"	\$5.38
PD265	17/64"	\$6.74
PD281	9/32"	\$7.00
PD296	19/64"	\$7.66
PD312	5/16"	\$7.40
PD328	21/64"	\$8.98
PD343	11/32"	\$9.66
PD359	23/64"	\$10.42
PD375	3/8"	\$9.65
PD390	25/64"	\$12.11
PD406	13/32"	\$12.31
PD421	27/64"	\$13.23
PD437	7/16"	\$13.64
PD453	29/64"	\$14.81
PD468	15/32"	\$15.41
PD484	31/64"	\$16.19
PD500	1/2"	\$14.52

Above Drills are straight shank

Acryl-Point™ Drills are specially manufactured to produce smooth holes in acrylic. The special Tip Angle allows for gradual penetration of material thus eliminating damage to back side of material. **Modified Rake Angle of 0° & Cutting Edge Clearance of 10° produces the smooth **CHIP FREE** hole required when working with acrylics.**

Large Size Acryl Point™ Drills

Part No.	Drill Size	Price
PD562	9/16"	\$18.16
PD625	5/8"	\$20.04
PD687	11/16"	\$35.24
PD750	3/4"	\$32.87
PD812	13/16"	\$45.32
PD875	7/8"	\$49.37
PD937	15/16"	\$55.48
PD100	1"	\$60.21

Above Drills Have 1/2" Shank

Drill Indexes Sold Seperate

Part No.	Holds	Price
10350	15pc/32nd	\$11.50
10550	29pc/64th	\$11.50
10760	8pc/Large	\$32.30

**CUSTOM DRILL BITS
AVAILABLE UPON REQUEST**

ACRYL-POINT DRILLS™ - NUMBERED

Part No.	Drill Size	Dec. Equiv.	Price
PDN228	1	0.228	\$6.29
PDN221	2	0.221	\$6.33
PDN213	3	0.213	\$5.98
PDN209	4	0.209	\$6.03
PDN205	5	0.205	\$6.03
PDN204	6	0.204	\$6.03
PDN201	7	0.201	\$5.41
PDN199	8	0.199	\$5.47
PDN196	9	0.196	\$5.47
PDN193	10	0.193	\$5.47
PDN191	11	0.191	\$5.26
PDN189	12	0.189	\$5.31
PDN185	13	0.185	\$5.26
PDN182	14	0.182	\$5.26
PDN180	15	0.180	\$5.26
PDN177	16	0.177	\$5.26
PDN173	17	0.173	\$5.26
PDN169	18	0.169	\$4.86
PDN166	19	0.166	\$4.86
PDN161	20	0.161	\$4.86
PDN159	21	0.159	\$4.70
PDN157	22	0.157	\$4.70
PDN154	23	0.154	\$4.39
PDN152	24	0.152	\$4.39
PDN149	25	0.149	\$4.29
PDN147	26	0.147	\$4.35
PDN144	27	0.144	\$4.29
PDN140	28	0.140	\$4.35

**P
L
E
X
I
P
O
I
N
T
D
R
I
L
L
S**

Part No.	Drill Size	Dec. Equiv.	Price
PDN136	29	0.136	\$4.19
PDN128	30	0.128	\$4.19
PDN120	31	0.120	\$4.09
PDN116	32	0.116	\$4.09
PDN113	33	0.113	\$4.09
PDN111	34	0.111	\$4.09
PDN110	35	0.110	\$4.09
PDN106	36	0.106	\$4.04
PDN104	37	0.104	\$4.04
PDN101	38	0.101	\$4.04
PDN099	39	0.099	\$4.04
PDN098	40	0.098	\$4.04
PDN096	41	0.096	\$4.04
PDN093	42	0.093	\$3.88
PDN089	43	0.089	\$3.88
PDN086	44	0.086	\$3.88
PDN082	45	0.082	\$3.88
PDN081	46	0.081	\$3.88
PDN078	47	0.0785	\$3.88
PDN076	48	0.076	\$3.88
PDN073	49	0.073	\$3.88
PDN070	50	0.070	\$3.88
PDN067	51	0.067	\$3.88
PDN063	52	0.063	\$3.88

10600	Drill Index Case / 52	\$12.50
-------	-----------------------	---------

DRILL SET - with Case

35000	All - 52pcs shown	\$243.15
--------------	--------------------------	-----------------

LETTERED ACRYL-POINT DRILLS™ METRIC

Part No.	Drill Size	Dec. Equiv.	Price
PDL234	A	0.2340	\$5.98
PDL238	B	0.238	\$6.74
PDL242	C	0.242	\$6.74
PDL246	D	0.246	\$6.74
PD250	E	0.250	\$5.38
PDL257	F	0.257	\$6.95
PDL261	G	0.261	\$7.41
PDL266	H	0.266	\$7.56
PDL272	I	0.272	\$7.56
PDL277	J	0.277	\$7.87
PDL281	K	0.2810	\$7.00
PDL290	L	0.290	\$8.48
PDL295	M	0.2950	\$8.74
PDL302	N	0.302	\$8.84
PDL316	O	0.316	\$8.94
PDL323	P	0.323	\$9.60
PDL332	Q	0.332	\$9.91
PDL339	R	0.339	\$10.32
PDL348	S	0.348	\$10.73
PDL358	T	0.358	\$11.70
PDL368	U	0.368	\$11.95
PDL377	V	0.377	\$12.46
PDL386	W	0.386	\$12.72
PDL397	X	0.397	\$14.50
PDL404	Y	0.404	\$15.73
PDL413	Z	0.413	\$16.54

10500	Drill Index Case / 26	\$11.30
-------	-----------------------	---------

DRILL SET - with Case

34000	All 26 letters	\$248.55
--------------	-----------------------	-----------------

P L E X I P O I N T D R I L L S

Part No.	Drill Size	Dec. Equiv.	Price
PDM078	2MM	0.0787	\$3.88
PDM098	2.5MM	0.0984	\$4.04
PDM118	3MM	0.1181	\$4.29
PDM137	3.5MM	0.1378	\$4.48
PDM157	4MM	0.1575	\$4.70
PDM177	4.5MM	0.1772	\$5.26
PDM196	5MM	0.1968	\$5.47
PDM216	5.5MM	0.2165	\$5.92
PDM236	6MM	0.2362	\$6.33
PDM255	6.5MM	0.2559	\$6.95
PDM275	7MM	0.2756	\$7.25
PDM295	7.5MM	0.2953	\$8.74
PDM315	8MM	0.3150	\$9.08
PDM334	8.5MM	0.3346	\$10.07
PDM354	9MM	0.3543	\$10.83
PDM374	9.5MM	0.3740	\$11.50
PDM393	10MM	0.3937	\$12.82
PDM413	10.5MM	0.4134	\$16.54
PDM433	11MM	0.4331	\$14.20
PDM452	11.5MM	0.4528	\$15.48
PDM472	12MM	0.4724	\$16.89
PDM492	12.5MM	0.4921	\$17.11
PDM511	13MM	0.5118	\$27.58

11150	Drill Index Case / 23	\$15.20
-------	-----------------------	---------

DRILL SETS - with Case

32000	12pc Set 2-13MM Whole#	\$124.15
33000	23pc Set / All Metric	\$230.25

**CUSTOM DRILL BITS
AVAILABLE UPON REQUEST**



WHITESIDE MACHINE CO.
ROUTER BITS MADE IN U.S.A.

ROUTER BITS FOR PLASTICS

Part No.	CED	CEL	SD	OAL	Price
----------	-----	-----	----	-----	-------

Flush Trim Straight Double B3 Bearing CT

2554 *	1/2"	1 1/2"	1/2"	3-7/8"	\$41.55
--------	------	--------	------	--------	---------

Flush Trim Spiral Double Bearing SC Upcut

RFT2100	1/4"	1"	1/4"	3"	\$33.50
---------	------	----	------	----	---------

RFT5125	1/2"	1 1/4"	1/2"	3 3/4"	\$65.90
---------	------	--------	------	--------	---------

Flush Trim Spiral Double Bearing SC Downcut

RFD2100	1/4"	1"	1/4"	3"	\$33.50
---------	------	----	------	----	---------

RFD5125	1/2"	1 1/4"	1/2"	3 3/4"	\$65.90
---------	------	--------	------	--------	---------

Flush Trim Straight CT B3 Bearing

2405	1/2"	1"	1/2"	3 3/4"	\$14.85
------	------	----	------	--------	---------

Flush Trim Straight CT B3 Bearing

2500 *	1/2"	1"	1/4"	2 1/2"	\$19.35
--------	------	----	------	--------	---------

Chamfer Bit 45° B3 Bearing

Part No.	Deg. of Angle	Cut Length	SD	OAL	Price
2302 (SC)	45°	5/8"	1/4"	2"	\$22.25
2305 (CT)	45°	5/8"	1/2"	2 1/4"	\$22.25

V Groove - 90° Included Angle

Part No.	Cut Diam.	Point Length	SD	OAL	Price
1500 (SC)	1/4"	1/8"	1/4"	1 1/2"	\$12.90
1502 (CT)	1/2"	1/4"	1/4"	1-7/8"	\$17.70

Corner Rounding CT B3 Bearing

Part No.	Radius	Cut Length	SD	Large Diam.	Price
2000	3/16"	1/2"	1/4"	7/8"	\$19.75
2001	1/4"	1/2"	1/4"	1"	\$19.75
2003	3/8"	5/8"	1/4"	1 1/4"	\$21.85
2009	1/2"	1/2"	1/2"	1 1/2"	\$26.85

Bearing Kits

B1A	Bearing Kit 1/4"	\$5.00
B3	Bearing Kit 1/2"	\$3.75

Part No.	CED	CEL	SD	OAL	Price
----------	-----	-----	----	-----	-------

Straight Bits SC V Flute

SC12	3/16"	5/8"	1/4"	2"	\$14.20
SC14	1/4"	3/4"	1/4"	2"	\$15.20
SC19	3/8"	1"	3/8"	2 1/2"	\$28.50
SC25	1/2"	1"	1/2"	3"	\$37.65

Standard Spiral SC Upcut

RU4100	3/8"	1"	3/8"	1 1/2"	\$27.65
RU5125	1/2"	1 1/4"	1/2"	3"	\$41.35

Standard Spiral SC Downcut

RD4100	3/8"	1"	3/8"	2 1/2"	\$27.65
RD5125	1/2"	1 1/4"	1/2"	3"	\$41.35

Slow Spiral SC Upcut

RU5150S*	1/2"	1 1/2"	1/2"	3 1/2"	\$50.10
----------	------	--------	------	--------	---------

Slow Spiral SC Downcut

RD5150S*	1/2"	1 1/2"	1/2"	3 1/2"	\$50.10
----------	------	--------	------	--------	---------

O-Flute Straight Bits Single Flute SC

SA1600	1/8"	3/8"	1/4"	2 1/2"	\$17.40
SA1800	3/16"	1/2"	1/4"	2 1/2"	\$17.40
SA2075	1/4"	3/4"	1/4"	2 1/2"	\$17.40

O-Flute Spiral SC Upcut

RU1600	1/8"	1/2"	1/4"	2"	\$16.50
RU2076A	1/4"	3/4"	1/4"	2 1/2"	\$18.95

O-Flute Spiral SC Downcut

RD1600	1/8"	1/2"	1/4"	2"	\$16.50
RD2076A	1/4"	3/4"	1/4"	2 1/2"	\$18.95

O-Flute Single Flute Spiral SC Upcut

RU2074A	1/4"	3/4"	1/4"	2 1/2"	\$18.95
---------	------	------	------	--------	---------

O-Flute Single Flute Spiral SC Downcut

RD2074A	1/4"	3/4"	1/4"	2 1/2"	\$18.95
---------	------	------	------	--------	---------

CEL = Cutting Edge Length SD = Shank Dia.

CED = Cutting Edge Dia.

OAL = Overall Length

SC = Solid Carbide

CT = Carbide Tipped

* 3 Flute Tool

ROUTER BITS FOR PLASTICS

ONSRUD CUTTERS

Part No.	CED	CEL	SD	OAL	Price
----------	-----	-----	----	-----	-------

Plastic Trim Double Bearing - Solid Carbide

28-20	1/4"	3/4"	1/4"	3"	\$43.00
28-25	1/2"	1-1/8"	1/2"	4"	\$118.55

FLUSH TRIM BIT w/Bearing - Carbide Tipped

28-54	1/2"	1"	1/2"	3 1/4"	\$25.85
28-57*	1/2"	1"	1/4"	2 3/4"	\$35.15
28-59*	1/2"	1 1/2"	1/2"	4 1/4"	\$35.40

Above 28-50 Series Use Replacement Bearing Kit #28-78
* 3 Flute Tools

CHAMFER BIT w/Bearing - Carbide Tipped Bevel

29-51	45°	5/8"	1/4"	2-1/16"	\$32.45
29-52	45°	5/8"	1/2"	2-1/16"	\$34.10

Above 29 Series Use Bearing Kit #28-78

V BOTTOM - Solid Carbide /Carbide Tipped

37-51	1/4"	3/4"	1/4"	2"	\$36.65
37-61	1/2"	13/32"	1/4"	2"	\$17.15

CORNER ROUNDING w/Bearing -Carbide Tipped Radius

42-01	3/16"	7/16"	1/4"	2"	\$33.00
42-02	1/4"	1/4"	1/4"	1-29/32"	\$33.80
42-05	3/8"	19/32"	1/4"	2-1/32"	\$35.75
42-07	1/2"	11/16"	1/2"	3"	\$45.05

Above 42 Series Use Bearing Kit #28-78

SINGLE EDGE Straight - Solid Carbide

61-062	3/16"	5/8"	1/4"	2"	\$27.75
61-082	1/4"	3/4"	1/4"	2 1/2"	\$28.95

DOUBLE EDGE Straight - Solid Carbide

56-062	3/16"	5/8"	1/4"	2"	\$24.85
56-082	1/4"	3/4"	1/4"	2 1/2"	\$26.15
56-122	3/8"	7/8"	3/8"	2 1/2"	\$48.80
56-162	1/2"	1"	1/2"	3"	\$76.50

Part No.	CED	CEL	SD	OAL	Price
----------	-----	-----	----	-----	-------

UPCUT- Double Edge - Solid Carbide O Flute

52-624	1/4"	3/4"	1/4"	2 1/2"	\$24.00
52-638	3/8"	1"	3/8"	3"	\$46.05
52-650	1/2"	1-1/8"	1/2"	3 1/2"	\$79.65

DOWNCUT- Double Edge - Solid Carbide O Flute

57-625	1/4"	3/4"	1/4"	2 1/2"	\$24.50
57-637	3/8"	1"	3/8"	3"	\$47.00
57-651	1/2"	1-1/8"	1/2"	3 1/2"	\$81.25

UPCUT THREE EDGE FINISHER - Solid Carbide

60-253	1/2"	1-5/8"	1/2"	4"	\$93.05
--------	------	--------	------	----	---------

DOWNCUT THREE EDGE FINISHER - Solid Carbide

60-250	1/2"	1-1/8"	1/2"	3 1/2"	\$84.25
--------	------	--------	------	--------	---------

UPCUT Single Edge SPIRAL O FLUTE

63-725	1/4"	3/4"	1/4"	2 1/2"	\$26.25
63-740	1/2"	1-5/8"	1/2"	3 1/2"	\$102.75

DOWNCUT Single Edge SPIRAL O FLUTE

62-725	1/4"	3/4"	1/4"	2 1/2"	\$26.25
62-740	1/2"	1-5/8"	1/2"	3 1/2"	\$113.50

SUPER O FINE FINISH BITS

UPCUT Single Edge SPIRAL

65-025	1/4"	7/8"	1/4"	2 1/2"	\$43.25
--------	------	------	------	--------	---------

DOWNCUT Single Edge SPIRAL

64-025	1/4"	3/4"	1/4"	2"	\$39.30
--------	------	------	------	----	---------

BEARING KITS

28-78 & 28-79	Replacement Bearing Kits	\$7.20 Ea
---------------	--------------------------	-----------

CEL = Cutting Edge Length SD = Shank Dia.

CED = Cutting Edge Dia. OAL = Overall Length

SOLVENT APPLICATOR BOTTLES

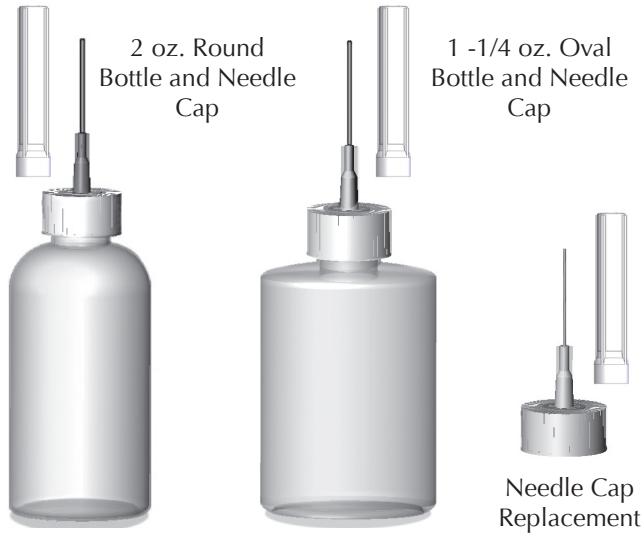

These LDPE needle cap applicators are available in an ergonomic 1-1/4 oz. oval, and a larger 2 oz. capacity round bottle. Both sizes are offered with either 23 or 25 gauge needle cap assemblies with a protective sheath. These bottles are ideal for water thin solvents and a favorite with Fabricators. Replacement needle cap assemblies may be purchased separately.

Needle Specifications			
Gauge	Color	ID	Length
23	Blue	.016"	1"
25	Orange	.012"	1"
Polypropylene hub with 304 stainless steel tubing.			

Part No.	Description	Each	12	50	100	250
OB23	1-1/4oz Oval Bottle with 23 Gauge Needle Cap	\$1.95	\$1.83	\$1.50	\$1.20	\$1.10
OB25	1-1/4oz Oval Bottle with 25 Gauge Needle Cap	\$1.95	\$1.83	\$1.50	\$1.20	\$1.10
RB23	2oz Round Bottle with 23 Gauge Needle Cap	\$1.95	\$1.83	\$1.50	\$1.20	\$1.10
RB25	2oz Round Bottle with 25 Gauge Needle Cap	\$1.95	\$1.83	\$1.50	\$1.20	\$1.10
NC23	23 Gauge Needle Cap Replacements	\$1.60	\$1.40	\$1.10	\$1.00	95¢
NC25	25 Gauge Needle Cap Replacements	\$1.60	\$1.40	\$1.10	\$1.00	95¢

Lure Cap with 2oz Round Bottle and Choice of Needle (3PC KIT)

Part No.	Description	Size	Each	25	50	100	250
LC2**	Lure Cap, Bottle & Needle, Kit	2oz	\$1.45	\$1.35	\$1.05	90¢	80¢

** For part number; Indicate needle gauge when ordering Lure Cap, Bottle & Needle Kit. Choose from 20, 23, 25 or 27 gauge. (Example "LC2-20" for 3 Pc. Kit with 20 gauge needle.)

Lure Cap and 2oz Round Bottle for KDS Needles

Part No.	Description	Each	12	50	100	250
LC512	Lure Cap (fits RB2 Bottle)	75¢	70¢	55¢	45¢	40¢
RB2	2oz Round Bottle (Bottle Only)	60¢	55¢	45¢	40¢	35¢

This Lure Cap System with 2 oz. round LDPE bottle accepts all our KDS needles, allowing the user to easily change the needle gauge from the very small KDS27 (used for fine work with water thin solvents) up to the KDS16 (for thicker solvents and gels). If it's a longer needle you're in search of, try this system with one of our 3" long needles available in both 23 and 25 gauge.

See list of KDS needles on page 20!



LC512 Lure Cap



SYRINGE APPLICATORS & NEEDLES

Syringe without Needle							
Part No.	Description	Size	Each	25	50	100	250
M10CCR	HD Syringe with Stopper	10cc	\$1.40	\$1.20	\$1.10	\$1.00	90¢
M10R	Replacement Stopper	N/A	70¢	60¢	55¢	50¢	45¢

KDS NEEDLES for LC512 Lure Cap and Syringe					
Part No.	Gauge	Length	Each	24	72
KDS16	16	1.5"	40¢	35¢	20¢
KDS20	20	1.5"	40¢	35¢	20¢
KDS23	23	1.5"	40¢	35¢	20¢
KDS25	25	1.5"	40¢	35¢	20¢
KDS27	27	1"	40¢	35¢	20¢
KDS23-3	23	3"	90¢	60¢	45¢
KDS25-3	25	3"	90¢	60¢	45¢

Needle Specifications		
Gauge	Color	ID
16	Purple	.053"
20	Yellow	.025"
23	Lt. Blue	.016"
25	Blue	.012"
27	Tan	.009"
Polypropylene lure lock hub with 304 stainless steel tubing.		

SCIGRIP - SOLVENTS

Description	Size	Part No.	Price
2354 Thin-bodied, fast setting cement for bonding ABS and styrene to themselves. UN 1193	Pt	10491	\$10.90
3 Non-flammable, water thin, very fast-setting solvent cement for bonding acrylics. Also bonds styrene, butyrate, PETG and polycarbonate to themselves. Will not bond to cross linked acrylics. UN 1593	Qt	12754	\$16.40
	Pt	10300	\$10.50
	4 oz	10799	\$5.70
45 ** 4:1 Cartridge - Requires Dispensing Gun Two part, high strength, reactive structural adhesive for bonding aluminum, galvanized steel, brass, copper, ABS, PVC, CPVC, PETG, polycarbonate and foam board to themselves and each other. UN 1133	43ml	12468	\$12.15
58 ** 1:1 Cartridge - Requires Dispensing Gun VOC-free, two part, fast-setting, reactive, urethane-based adhesive for bonding polycarbonate, butyrate, ABS and PETG to themselves and each other. Excellent UV light resistance. UN None	50ml	12373	\$20.15

**** Dispensing Gun and Mixing Tip** with Weld-On 45 and 58 makes applications easy and efficient. Adhesive is mixed as it passes through the mixing tip. It is not necessary to use entire cartridge at one time.

Description	Part No.	Price
Dispensing Gun for #45 @ 4:1 & #58 @ 1:1	13585	\$60.90
Straight Mixing Tip	11195	\$1.05

NOTE: Other Adhesives and Cements available upon request. Minimums will apply.

HINGES

Micro Dots®

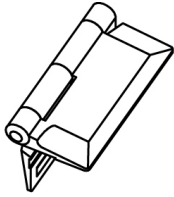

SHCB Acryl-Hinge Small™

Size: 1-3/8" x 1-1/2"

1 Pair	100 Pairs	600 Pairs	1,200 Pairs	1,800 Pairs
70¢	50¢	44¢	39¢	36¢

Color: Clear Only

Material: High Strength DR Acrylic

Micro Dots®

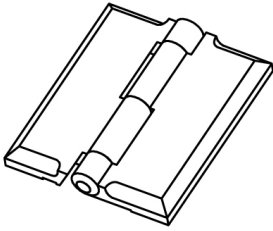

Acryl-Hinge 2™

Size: 1-1/2" x 1-3/4"

AHCB - Clear AHBB - Black AHWB - White

1 Pair	100 Pairs	600 Pairs	1,200 Pairs	1,800 Pairs
75¢	55¢	49¢	45¢	42¢

Color: Clear, Black and White

Material: High Strength DR Acrylic

Micro Dots®

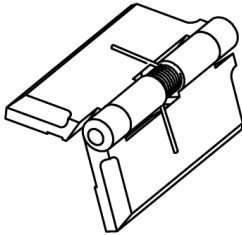

AHCS Acryl-Hinge 2™ with Spring

Size: 1-1/2" x 1-3/4"

1 Pair	100 Pairs	600 Pairs	1,200 Pairs	1,800 Pairs
85¢	68¢	59¢	55¢	52¢

Color: Clear Only

Material: High Strength DR Acrylic



FFH2/4050 Flex-Fold 2™ 40½" Length

Size: 3/16" x 1-7/16"

Each	25	100	200	300
\$7.00	\$6.20	\$5.50	\$5.00	\$4.50

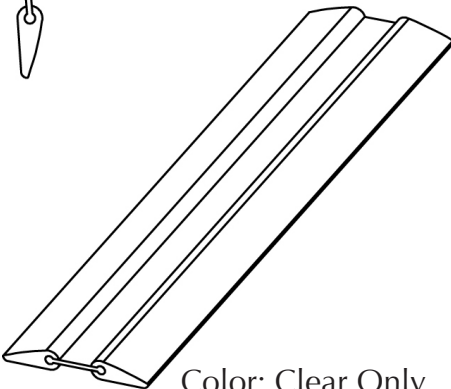

FFH2 Flex-Fold 2™ 48" Length

Size: 3/16" x 1-7/16"

\$8.30	\$7.30	\$6.50	\$5.90	\$5.35
--------	--------	--------	--------	--------

FFH2/72 Flex-Fold 2™ 72" Length

Size: 3/16" x 1-7/16"

\$12.30	\$10.80	\$9.65	\$8.90	\$7.95
---------	---------	--------	--------	--------

Material: Urethane Elastomer center and MI-7® High-Impact Acrylic sides.

Flex-Fold 2™ is a transparent, all weather, and continuous plastic hinge with rugged durability. It is especially well suited for use in extreme climates from tropical to arctic cold. **The Flex-Fold2™** is recommended for bulk food bins, pastry cases, golf cart windshields, and freezer compartments, as well as marine and other outdoor applications.

PIANO HINGES

The **6" & 12" Acryl-Hinges** are designed with our trademark Micro Dots® that create a gap between the hinge and cementing surface to improve solvent flow. Acryl-Hinges are molded using High Strength Acrylic for superior strength, and feature ultra-flat glue surfaces that makes bonding quick and trouble free. The hinge pins are self-lubricating acrylic and splined at one end to prevent them from working loose. The sleek low profile design offers a clean and finished look your customers will appreciate.

6" Acryl-Hinge™

Size: 1½" x 6"

AHC6 - CLEAR AHB6 - BLACK AHW6 - WHITE

Each	50	100	400	1,200
89¢	79¢	69¢	59¢	54¢

Color: Clear , Black and White

Material: High Strength DR Acrylic

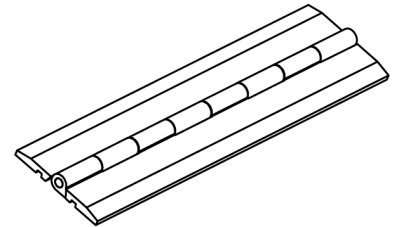

Micro Dots®

Patent No.: US D623 041 S

AHC6S 6" Acryl-Hinge™ with SPRING

Size: 1½" x 6"

Each	50	100	400	1,200
\$1.05	95¢	90¢	85¢	80¢

Color: Clear Only

Material: High Strength DR Acrylic

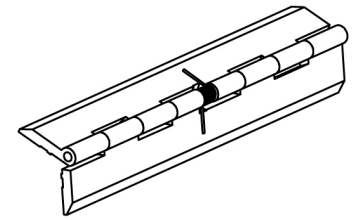

Micro Dots®

Patent Pending

12" Acryl-Hinge™

Size: 1½" x 12"

AHC12 - CLEAR AHB12 - BLACK AHW12 - WHITE

Each	50	100	400	800
\$1.59	\$1.38	\$1.20	99¢	92¢

Color: Clear , Black and White

Material: High Strength DR Acrylic

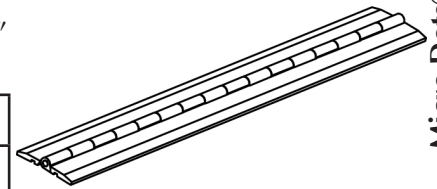

Micro Dots®

Patent No.: US D623 041 S

AHC12S 12" Acryl-Hinge™ with 2 SPRINGS

Size: 1½" x 12"

Each	50	100	400	800
\$1.80	\$1.60	\$1.45	\$1.15	\$1.05

Color: Clear Only

Material: High Strength DR Acrylic

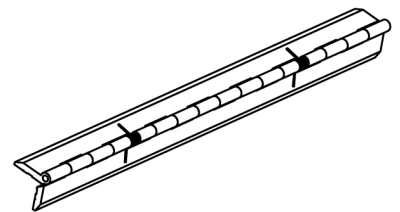

Micro Dots®

Patent Pending

12" Piano Hinge

Size: 1¾" x 12"

H12CL - CLEAR H12BK - BLACK H12WH - WHITE

Each	50	100	500	1,000
\$1.85	\$1.53	\$1.35	\$1.05	98¢

Color: Clear , Black and White

Material: Acrylic

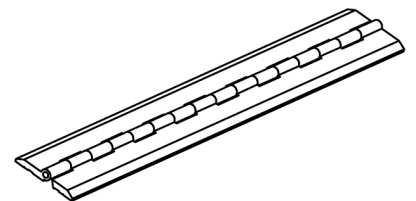

HANDLES & KNOBS

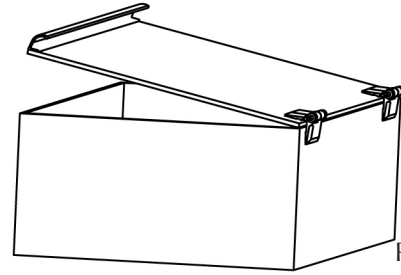
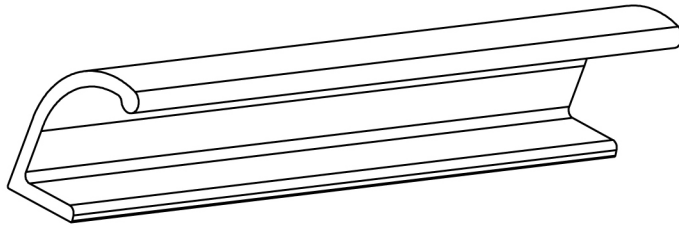

Patent D493687S

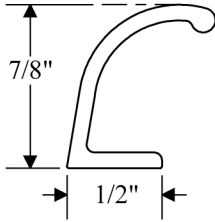

HBC100 Handle Bar - 24" Lengths

Each	48	96	192	384
\$1.95	\$1.60	\$1.50	\$1.35	\$1.20

Color: Clear Only

Material: High Strength Acrylic

Micro Dots®

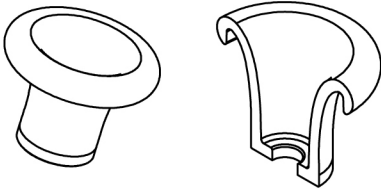

AKC100 Acryl-Knob™ with 3/16" Hole

Size: 1" x 3/4"

Each	100	600	1,200	1,800
32¢	26¢	24¢	22¢	20¢

Color: Clear Only

Material: High Strength Acrylic

Micro Dots®

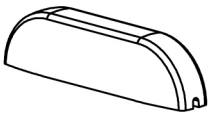

Acryl-Pull Handle™-Small

Size: 3/8" x 2"

AP3C - CLEAR AP3B - BLACK AP3W - WHITE

Each	100	600	1,200	1,800
55¢	50¢	45¢	40¢	35¢

Micro Dots®

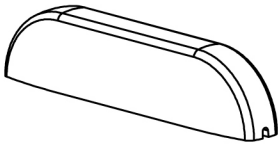

Acryl-Pull Handle™-Medium

Size: 7/16" x 2 3/4"

AP2C - CLEAR AP2B - BLACK AP2W - WHITE

Each	100	600	1,200	1,800
65¢	55¢	50¢	45¢	40¢

Micro Dots®

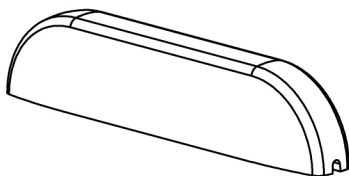

Acryl-Pull Handle™-Large

Size: 1/2" x 3 1/2"

AP1C - CLEAR AP1B - BLACK AP1W - WHITE

Each	100	600	1,200	1,800
70¢	60¢	55¢	50¢	45¢

Note: All PULLS are manufactured from High Strength DR Acrylic

HASPS & CATCHES

106HCA Acryl-HASP™ (assembled) **Size:** 15/16" x 2-3/16"

Each	50	100	500	1,000
85¢	74¢	65¢	60¢	55¢

Color: Clear Only

Material: High Strength DR Acrylic

Micro Dots®

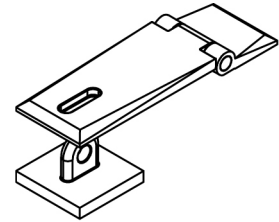

Patent No.: US D604, 142 S

104HCA HASP (assembled) **Size:** 1" x 2 1/4"

Each	50	100	500	1,000
90¢	80¢	70¢	65¢	60¢

Color: Clear Only

Material: High Strength Acrylic

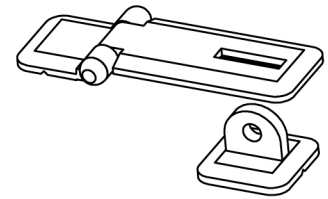

PL625NP Nickel Plated Pad Lock Supplied with 2 Keys

Each	25	100	250	500
65¢	55¢	50¢	45¢	43¢

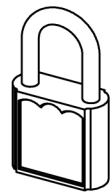

PL750 Solid Brass Pad Lock Supplied with 2 Keys

Each	25	100	250	500
\$1.55	\$1.30	\$1.20	\$1.15	\$1.12

SEE PAGE 32 for more Pad Lock Information

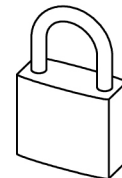

68DC Door Catch **Size:** 1/2" x 1"

Each	50	100	500	1,000
60¢	45¢	32¢	24¢	20¢

Color: Clear Only

Material: High Strength DR Acrylic

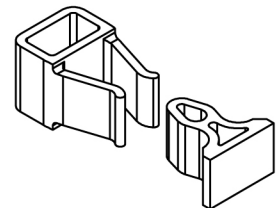

PC1 Poly Catch 1 **Size:** 1 1/16" x 3/4"

Each	50	100	500	1,000
55¢	34¢	31¢	29¢	25¢

Color: Clear Only

Material: Polycarbonate

Patent No.: US D419, 423 S



HANGERS

Micro Dots®

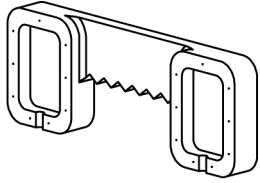

Patent No.: US D633,372

WH2 Acryl-Wall Hanger™

Size: 3/4"H x 2"W x .200"D

Each	25	100	500	1,000
45¢	35¢	25¢	20¢	15¢

Color: Clear Only

Material: High Strength DR Acrylic

Micro Dots®

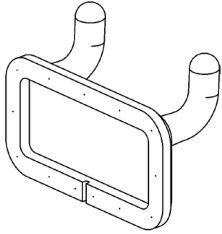

PH4 Acryl-Peg Hook™

Size: 3/4"H x 1-3/8"W x 1/8"D

Each	25	100	500	1,000
26¢	23¢	19¢	15¢	12¢

Color: Clear Only

Material: High Strength DR Acrylic

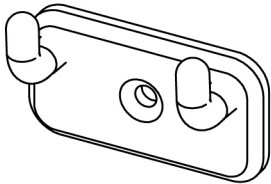

PH3 Pegboard/Slatwall Hook

Size: 3/4"H x 1-3/8"W x 1/8"D

Each	25	100	500	1,000
35¢	30¢	28¢	25¢	22¢

Color: Clear Only

Material: High Strength DR Acrylic

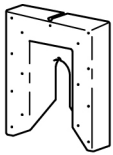

KHA100 KeyHole Attachment

Size: 7/8"H x 3/4"W x 3/16"D

Each	25	100	500	1,000
18¢	14¢	12¢	11¢	10¢

Color: Clear Only

Material: High Strength DR Acrylic

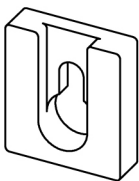

KHA200 KeyHole Attachment

Size: 1"H x 7/8"W x 1/4"D

Each	25	100	500	1,000
20¢	17¢	14¢	13¢	12¢

Color: Clear Only

Material: High Strength DR Acrylic

Micro Dots®

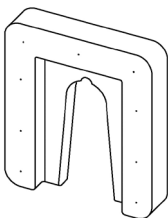

NEW KHA300 Acryl-Hanger™

Size: 1"H x 7/8"W x 3/16"D

Each	25	100	500	1,000
18¢	14¢	12¢	11¢	10¢

Color: Clear Only

Material: High Strength DR Acrylic

OPTICAL NOSE PIECE HOLDERS

Authorized Ennco Display Systems Distributor

9001RG 5/8" Nasals - Glue on Rod Mount

Size: 1-1/2" x 1" x 1/2"

Each	100	500	1,000
50¢	40¢	38¢	34¢

Material: Clear Acrylic

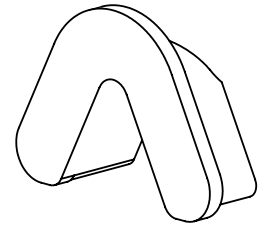

9001RG & 9002RG

9002RG 7/8" Nasals - Glue on Rod Mount

Size: 1-1/2" x 1" x 1/2"

Each	100	500	1,000
70¢	60¢	55¢	50¢

Material: Clear Acrylic

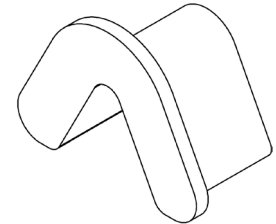

9003FG 5/8" Nasals - Glue on Rod Mount

Size: 1-1/2" x 1" x 3/4"

Each	100	500	1,000
70¢	60¢	55¢	50¢

Material: Clear Acrylic

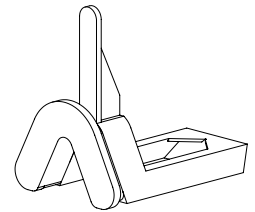

9003FG

*9005AG High Standard - Flat Surface Mount

Size: 1-1/2" x 2" x 2-3/8"

Each	100	500	1,000
50¢	40¢	38¢	34¢

New Lower Price

Material: Clear Acrylic

9005AG

*9006AH POP Nasal 45° - Flat Surface Mount

Size: 1-3/8" x 1-7/8" x 3"

Each	100	500	1,000
70¢	65¢	60¢	55¢

New Lower Price

Material: Clear Acrylic

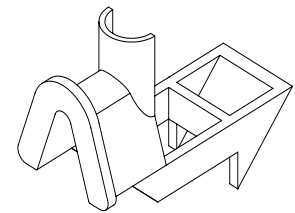

9006AH

9007FH POP Nasal Straight - Flat Surface Mount

Size: 1-3/8" x 1-7/8" x 2-1/8"

Each	100	500	1,000
90¢	85¢	80¢	70¢

Material: Clear Acrylic

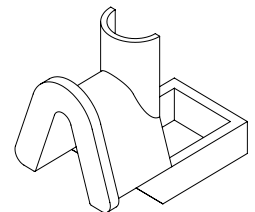

9007FH

9015RC 5/8" Rod Clip On Holder

Size: 1-1/2" x 1-1/8" x 1-1/8"

Each	100	500	1,000
\$1.75	\$1.49	\$1.40	\$1.23

Material: Clear Acrylic

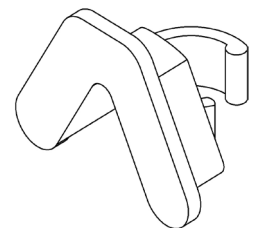

9015RC & 9016RC

9016RC 7/8" Rod Clip Holder

Size: 1-1/2" x 1-3/16" x 1-3/8"

Each	100	500	1,000
\$1.75	\$1.49	\$1.40	\$1.23

Material: Clear Acrylic

* Limited to stock on hand

FTM - Fabrication Tools & Materials

Phone: (530) 626-1986 | Fax: (530) 642-2602

SUCTION CUPS

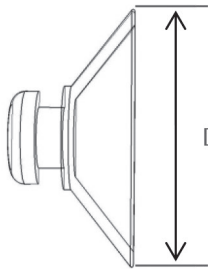

Diameter

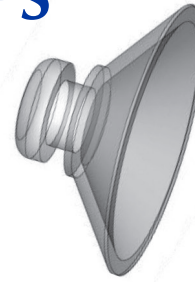
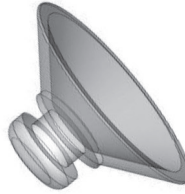

6005

Part No.	Description	Dia.	Each	100	500	1,000
SCM04	Sm. Suction Cup	7/8"	10¢	\$7.00	\$27.40	\$46.00
SCM03	Md. Suction Cup	1-1/4"	12¢	\$8.80	\$39.80	\$67.00
SCM02	Lg. Suction Cup	1-3/4"	15¢	\$11.40	\$52.00	\$89.00
SCM01	XL. Suction Cup	2-1/4"	26¢	\$20.50	\$93.50	\$159.00
6005	Wire Hook		7¢	\$4.95	\$22.50	\$38.00
6006	Nylon Tack	5/8"	9¢	\$6.75	\$30.50	\$51.00
6007	Styrene Tack	11/16"	5¢	\$3.95	\$16.50	\$27.60



6006



6007

Suction Cup Hardware Compatibility Chart

Part No.	See Above			See Page 38		See Page 25	
	Nylon Tack	Styrene Tack	Wire Hook	H625R	H750F	KHA100	KHA300
SCM04				✓		✓	
SCM03	✓	✓					✓
SCM02	✓	✓	✓		✓		
SCM01	✓	✓	✓		✓		

SPLIT MICROFIBER

The Ultimate Cleaning Cloth

Part No.	Description	Each	12	24	72
801TT	Terry Towel - Super Absorbent - Green 12" x 12"	\$2.00	\$1.67	\$1.54	\$1.43
803SA	Suede Cloth - (No Fray) - Lt Blue 12" x 12"	\$1.55	\$1.30	\$1.20	\$1.10
805GW	Cleaning Gloves - White	\$3.31	\$2.76	\$2.55	\$2.37

Part No.	Color	Usage
801TT	Green	All purpose wiping of dust or loose particles, before using any product. Super Absorbent, Super Soft Wash Cloth.
803SA	Light Blue	For final polish when using Novus #1 , #2, or #3 & Brilliantize. Also good for Eye Glasses, CDs, Camera Lenses, and LCD Screens.
805GW	White	Use when Applying Novus #1 & Brilliantize.

CLEANERS • SCRATCH REMOVERS

NOVUS

Part No.	Description	Each	12	24	72
#1 for Polishing & Cleaning Also Anti-static, Anti-fog & Dust Repellent					
7020	#1 Polish / Cleaner 8oz Pump (24)	\$3.70	\$3.20	\$2.95	\$2.85
7026	#1 Polish / Cleaner 2oz Squeeze (48)	\$1.85	\$1.60	\$1.45	\$1.40
7050	#1 Polish / Cleaner 1/2 Gallon Refill (12)	\$14.00	\$12.35	\$11.35	\$11.05
#2 for Removing Fine Scratches					
7030	#2 Scratch Remover / Polish 8oz (24)	\$5.25	\$4.55	\$4.15	\$4.00
7033	#2 Scratch Remover / Polish 2oz (48)	\$2.70	\$2.35	\$2.10	\$2.05
7072	#2 Scratch Remover / Polish 1/2 Gallon (12)	\$26.95	\$23.45	\$21.30	\$20.60
#3 for Heavy Scratch Removal					
7080	#3 Scratch Remover 8oz (24)	\$6.25	\$5.40	\$4.90	\$4.70
7081	#3 Scratch Remover 2oz (48)	\$3.15	\$2.75	\$2.50	\$2.40
7082	#3 Scratch Remover 1/2 Gallon (12)	\$30.70	\$26.70	\$24.20	\$23.40

Part No.	Description	Each	50	250	500
7300	Micro Filament Premium Cloth 13" x 13" (25)	90¢	80¢	75¢	70¢

About Micro-Filament

Using the wrong cloth when cleaning plastics can damage the surface. Standard paper toweling, polyester or rayon cloths leave scratches in plastics. Eliminate this problem with a reusable Micro Filament Premium Cloth. These soft cloths are highly absorbent, anti-scratch, low lint and extra durable. When a Micro-Filament Cloth gets dirty, simply wash out with soap and water, and air dry.

KLEENMASTER BRILLIANIZE

Part No.	Description	Each	12	24	72
8	Kleenmaster Brillianize 8oz Pump Bottle (12)	\$4.35	\$3.80	\$3.50	\$3.35

Part No.	Description	Each	4	8	12
128P	Kleenmaster Brillianize Gallon Refill (4)	\$21.00	\$18.00	\$17.00	\$16.00

COTTON WORK GLOVES ON PAGE 30

Reduce clean-up time by eliminating fingerprints on fabricated parts.

BUFFING COMPOUNDS

All compounds are sold in 2"x 2½"x 10¼" Bars - Approx. Weight for each compound is listed.

Part No.	Item	Description	Weight	Each	6	12
----------	------	-------------	--------	------	---	----

FINAL FINISH COMPOUNDS

CORO-6	White - Rouge C-15	Medium Wet	3.28 LB	\$8.00	\$6.98	\$6.60
--------	--------------------	------------	---------	--------	--------	--------

Use: Most popular for use on Acrylic Sheet or where a smooth, scratch-free finish is desired.

CORO-3	Blue - Rouge-1	Medium Dry	3.19 LB	\$8.00	\$6.98	\$6.60
--------	----------------	------------	---------	--------	--------	--------

Use: Very popular for use on Acrylic Sheet or where a smooth, scratch-free finish is desired.

BASIC FINISH COMPOUNDS - FAST CUTTING

COTR-1	Red - Tripoli #6	Medium Dry	2.21 LB	\$3.30	\$2.90	\$2.75
--------	------------------	------------	---------	--------	--------	--------

Use: Most popular - Excellent fast cutting on plastic. Used before finish compounds.

COPL-1	Beige 2-F	Wet	2.50 LB	\$4.15	\$3.70	\$3.50
--------	-----------	-----	---------	--------	--------	--------

Use: Sharp, Superb for use on rough Acrylic Sheet. Leaves work clear and clean.

BEWARE NOT ALL BARS ARE CREATED EQUAL: Heavier weight bars can contain more fillers and less cutting compounds. What you save in cost now will cost you MORE in lost time at the buffing wheel.

BUFFING WHEELS

All Buffs have a 1" arbor hole size

Part No.	Description	Each	6	12
B1060	10" x 60 Ply Loose Buff	\$15.20	\$13.90	\$12.80
B1080	10" x 80 Ply Loose Buff	\$18.90	\$17.50	\$16.40
B1040S	10" x 40 Ply 1" Concentric Stitched Buff	\$14.75	\$13.55	\$12.55
1901	Rake, for cleaning buffs	\$14.50	\$13.00	\$11.95

Bufs consist of **LAYERS** of Cotton Muslin with a weave of 60/60 and a Fine Raked Edge. This provides a **LONGER LASTING BUFF**.

NOTE: Concentric stitched buffs eliminate the HARD spot that spiral stitched buffs have.

TAPES

INTERTAPE Double Coated Tapes - Heavy-Duty (12 mil)

Part No.	Description	Each	12	48	96
591/500	12MM (1/2") wide x 36 yards	\$4.25	\$3.90	\$3.55	\$3.40
591/750	18MM (3/4") wide x 36 yards	\$6.25	\$5.75	\$5.20	\$5.00
591/100	24MM (1") wide x 36 yards	\$8.35	\$7.70	\$6.95	\$6.65
591/200	48MM (2") wide x 36 yards	\$16.65	\$15.40	\$13.90	\$13.35

MICRO-SURFACE FINISHING PRODUCTS

- Removes swirls & scratches created by improper cleaning methods.
- Removes haze and milkiness from interior / exterior windows.
- Provides a final polish, leaving you with an ultra-clear finish.
- Can be applied by hand or mechanically.
- Approved for use by Boeing, Spec. D6-52021.
- Approved for military use, NSN #5350-01-334-8997.

RESTORE TRANSPARENCY to CLEAR & COLORED ACRYLICS
RESTORE SURFACE FINISH & REMOVE MINOR DAMAGE ON ACRYLICS

Part No.	Description	Price
KR-70	Acrylic Surface Restoral Kit - Restores up to 30 Sq. Ft.	\$26.50
3KAQK	Aquarium Kit - restores up to 20 Sq. Ft.	\$18.00
3KCount	Countertop Repair Kit	\$9.00

NOTE: Kits for both hand and mechanical application methods are available.

COTTON WORK GLOVES

Greatly reduces clean up time by eliminating fingerprints on fabricated parts.
 Available in Men's or Women's sizes. Gloves are sold by the Dozen Pair Only.

Part No.	Description	Each	6	12
712N	Men's Size	\$5.95DZ	\$5.60DZ	\$4.95DZ
711N	Women's Size			

METAL CAM LOCKS AND CAMS

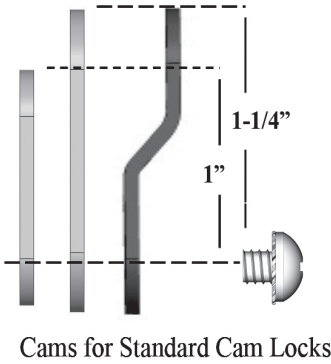
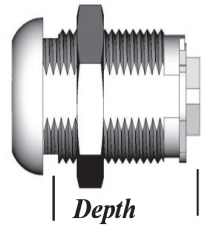
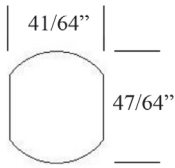

Cams for Standard Cam Locks



CAM100

CAM250

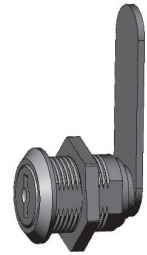
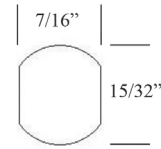

Mini Cam Locks

Supplied with 2 keys, Mounting Nut and 1" Flat Cam

Note: Use Drill #PD468 for mounting hole

Standard Cam Locks

Supplied with 2 keys, Mounting Nut

Note: Use Drill #PD750 for mounting hole



TR100



WS100W

Lock Depth Mounting Guide

Lock Depth	Material Thickness
7/16"	.100" and Thinner
5/8"	.250" and Thinner
7/8"	.500" and Thinner

Part No.	Description	Each	25	100	250
MCL625/370	Mini Cam Lock, key code 370, 5/8" depth (Chrome)	\$1.40	\$1.15	\$1.05	98¢
MCL625/W23	Mini Cam Lock, key code W23, 5/8" depth (Chrome)	\$1.40	\$1.15	\$1.05	98¢
CL437/679	Standard Cam Lock, key code 679, 7/16" depth (Chrome)	\$2.25	\$1.85	\$1.75	\$1.55
CL437/93	Standard Cam Lock, key code 93, 7/16" depth (Chrome)	\$2.25	\$1.85	\$1.75	\$1.55
CL625/679	Standard Cam Lock, key code 679, 5/8" depth (Chrome)	\$2.25	\$1.85	\$1.75	\$1.55
CL625/93	Standard Cam Lock, key code 93, 5/8" depth (Chrome)	\$2.25	\$1.85	\$1.75	\$1.55
CL875/93	Standard Cam Lock, key code 93, 7/8" depth (Chrome)	\$2.45	\$2.00	\$1.85	\$1.70
CAM100	Cam 1" Length "0" offset (Fits Standard Cam Locks)	26¢	21¢	19¢	18¢
CAM125	Cam 1 1/4" Length "0" offset (Fits Standard Cam Locks)	26¢	21¢	19¢	18¢
CAM250	Cam 1 1/4" Length 1/4" offset (Fits Standard Cam Locks)	26¢	21¢	19¢	18¢
WS100W	Double "D" Wood Washer (Fits Standard Cam Locks)	26¢	21¢	19¢	18¢
TR100C	Trim Ring - Chrome (Fits Standard Cam Locks)	26¢	21¢	19¢	18¢

SHOWCASE LOCK

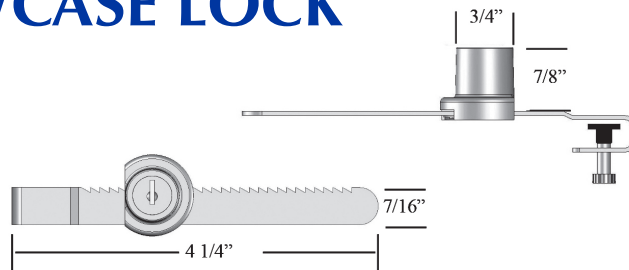
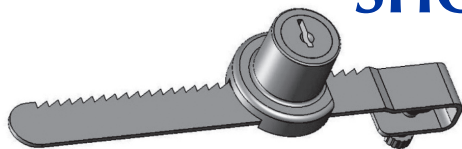

Part No.	Description	Each	25	100	250
SC450	Showcase Lock for bypass doors (Chrome Finish)	\$2.80	\$2.35	\$2.05	\$1.90

NEW ACRYLIC CAM LOCK

Patent Pending

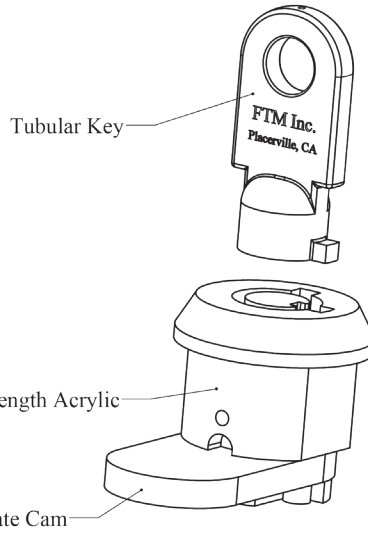
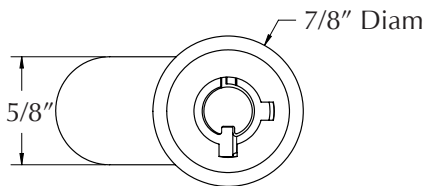
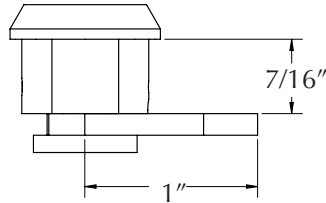
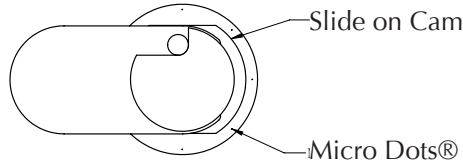

First Ever! ACRYLIC CAM LOCK

- High Strength Acrylic
- Solvent Cementable
- Micro Dots®
- Polycarbonate Cam and Internal Parts
- 90° Rotation
- Tubular Key
- Labor Saving

Supplied with 1 key and 1" Flat Cam

Note: use drill PD750 for mounting hole

INTRODUCING from FTM THE FIRST EVER SOLVENT CEMENTABLE CAM LOCK

Designed with Micro Dots® to be solvent cementable, this new concept offers labor savings and a fresh new look for your displays. All internal parts are made with polycarbonate for superior strength, and a high strength acrylic housing for easy solvent cementing. The Double D shaped housing fits a standard cam lock hole, or use a 3/4" drill **PD750 (page 14)** for a round hole. When a round hole is used the flat side of the cam lock can be used to ensure proper alignment.

Why solvent bond a cam lock? Solvent bonding stops cracking problems caused by an over tightened mounting nut, and a solvent bonded lock won't turn when installed in a round hole. **Try one on your next display.**

Part No.	Description	Each	25	100	250	500	1,000
ACL100T	NEW! Acryl-Cam Lock™ w/ 1" Flat Cam	\$1.20	98¢	89¢	80¢	75¢	65¢

PAD LOCKS

Nickel Plated Pad Lock

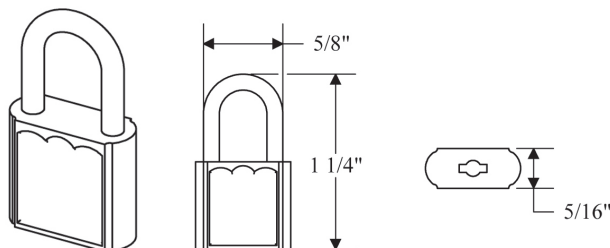

Solid Brass Pad Lock

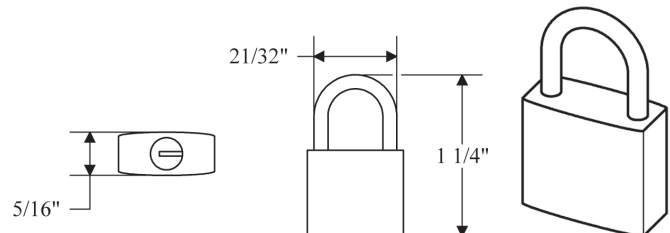

Part No.	Description	Each	25	100	250	500	1,000
PL625NP	Nickel Plated Pad Lock	65¢	55¢	50¢	45¢	43¢	41¢
PL750	Solid Brass Pad Lock	\$1.55	\$1.30	\$1.20	\$1.15	\$1.12	\$1.10

BUSINESS CARD HOLDERS

(CLEAR ACYRLIC)

M51 Premium

Gluing Surface is Within .004" FLAT

Micro Dots®

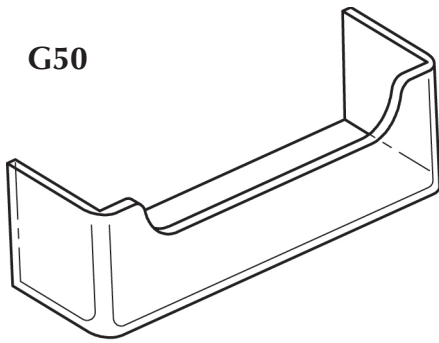

G50

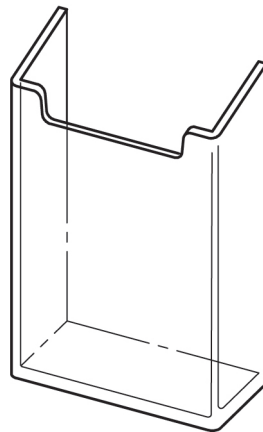

G71

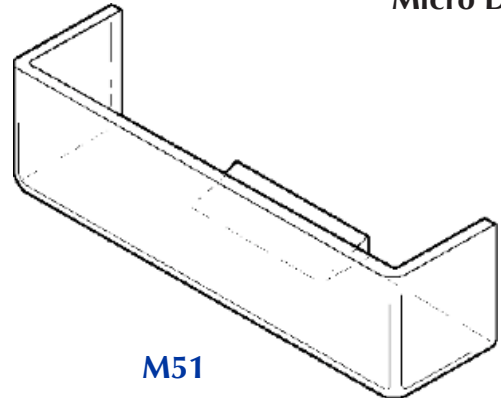

M51

LITERATURE HOLDERS

(CLEAR ACYRLIC)

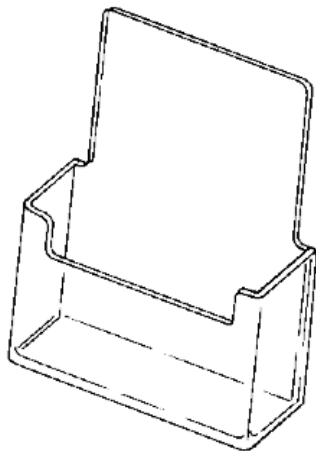

WALL-MOUNTED
M101 & M121

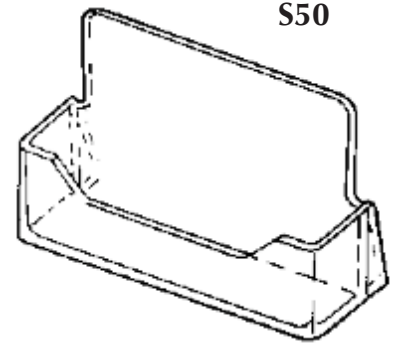

S50

FREE-STANDING
S100 & S120

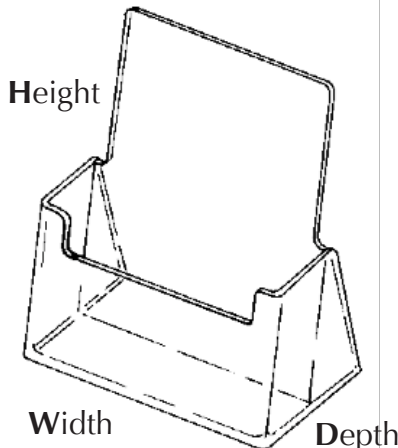

Part No.	"H"	"W"	"D"	Each	25	100	500
----------	-----	-----	-----	------	----	-----	-----

Free-Standing Holders

S100	7¼"	4-1/8"	1¼"	\$1.35	\$1.15	\$1.00	90¢
S120	9¼"	8¾"	1-3/8"	\$2.40	\$2.00	\$1.75	\$1.60

Wall Mounted Holders

M101	7¼"	4¼"	1¼"	\$1.80	\$1.50	\$1.30	\$1.20
M121	9-3/8"	9"	1-1/8"	\$3.95	\$3.35	\$2.90	\$2.70

Business Card Holders

				Each	100	500	1,000
M51	7/8"	3-5/8"	7/8"	43¢	36¢	31¢	28¢
G50	7/8"	3-5/8"	11/16"	46¢	42¢	35¢	32¢
G71	3½"	2¼"	1"	\$1.20	\$1.00	90¢	80¢
S50	2"	3¾"	11/16"	43¢	36¢	31¢	28¢

OUTDOOR REAL ESTATE BOXES

Clear Front and Ivory Lid & Back

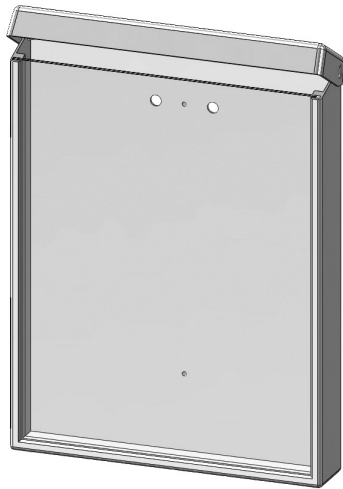

ODL300
Removable Front

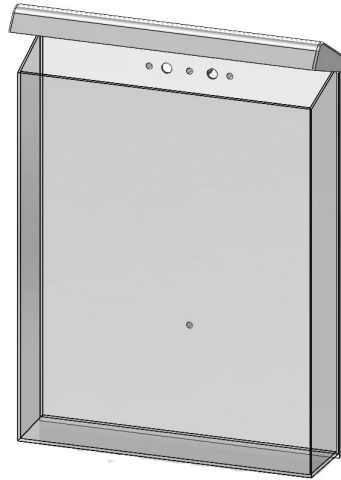

ODR100 &
ODR200

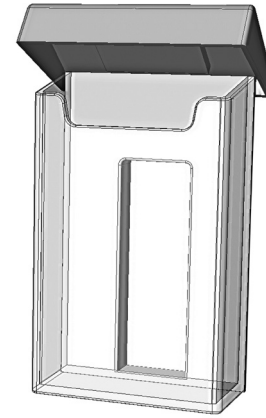

BC1
Business Card
Pocket

SAVE TIME & MONEY BY USING GLUE ON CARD POCKETS

GLUE ON CARD POCKETS

(CLEAR ACYRLIC)

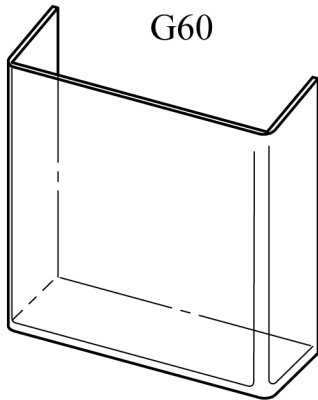

G60

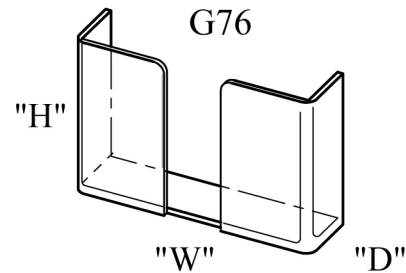

G76

"H"

"W"

"D"

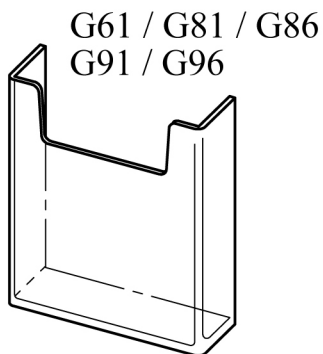

G61 / G81 / G86
G91 / G96

Part No.	Size H - W - D	Each	25	100	500
BC1	3-3/8" x 2-1/4" x 1"	\$3.25	\$3.00	\$2.80	\$2.60
ODR100	9" x 4-5/8" x 1-7/8"	\$7.85	\$6.80	\$6.35	\$6.00
ODR200	11" x 8-5/8" x 1-7/8"	\$11.15	\$9.60	\$8.90	\$8.35
ODL300	11" x 8-5/8" x 1"	\$8.00	\$7.00	\$6.60	\$6.20
G60	5" x 4-3/8" x 1 1/2"	\$1.10	95¢	80¢	75¢
G61	4" x 4" x 1"	90¢	80¢	70¢	65¢
G76	2-5/8" x 3-7/8" x 1"	\$1.15	\$1.00	85¢	80¢
G81	4" x 3 1/4" x 1"	70¢	60¢	50¢	47¢
G86	5-5/8" x 5-5/8" x 1 1/2"	\$1.70	\$1.45	\$1.25	\$1.15
G91	2-3/8" x 2 1/2" x 1"	50¢	42¢	37¢	34¢
G96	9 3/4" x 8 3/4" x 1-7/8"	\$3.90	\$3.30	\$2.85	\$2.70

Note: All Dimensions are I.D.

BSI BUMPERS

Part No.	Dia. / Height	Shape	Pad each	1 case	2 - 5	6 - 9	10 - Up
BS-27 5400 per case	.312" (7.9mm) .085" (2.2mm)	Hemisphere	\$10.90 per 450 pcs	\$80.25 case \$14.86/M	\$78.00 case \$14.44/M	\$72.00 case \$13.33/M	\$70.20 case \$13.00/M
BS-2 5082 per case	.44" (11.1mm) .20" (5.0mm)		\$9.45 per 242 pcs	\$120.50 case \$23.71/M	\$117.15 case \$23.05/M	\$108.15 case \$21.28/M	\$105.45 case \$20.75/M
BS-12 7200 per case	.375" (9.5mm) .150" (3.8mm)		\$12.40 per 288 pcs	\$186.15 case \$25.85/M	\$181.00 case \$25.14/M	\$167.10 case \$23.21/M	\$162.90 case \$22.63/M
BS-1 5000 per case	.50" (12.7mm) .14" (3.5mm)	Cylindrical	\$8.40 per 200 pcs	\$127.15 case \$25.43/M	\$123.60 case \$24.72/M	\$114.10 case \$22.82/M	\$111.25 case \$22.25/M
BS-20 5082 per case	.400" (10.2mm) .100" (2.5mm)	Square	\$8.05 per 242 pcs	\$101.65 case \$18.82/M	\$98.80 case \$18.30/M	\$91.20 case \$16.89/M	\$88.95 case \$16.47/M
BS-32 5000 per case	.50" (12.7mm) .120" (3.0mm)		\$7.45 per 200 pcs	\$111.45 case \$20.64/M	\$108.35 case \$20.06/M	\$100.00 case \$18.52/M	\$97.50 case \$18.06/M

Transparent

Self-Adhesive, Polyurethane Molded Bumpers with Acrylic Adhesive

Superb Coefficient of Friction & Resistance to Skidding

UL Recognized Compound

Easy 'Peel-Off' Application

Superior Abrasion Resistance

Crack-Resistant & Resilient

Non-Staining & Non-Marring

Vibration & Shock Dampening

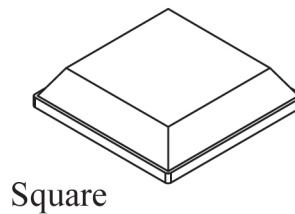

Cylindrical



Hemisphere

3M BUMPONS™

Transparent **3M** Bumpon™

Authorized **3M** Distributor

Part No.	Dia. / Height	Shape	Pad each	1 case	2 - 5	6 - 9	10 - Up
SJ-5302 3024 per case	.312" (7.9mm) .085" (2.2mm)	Hemisphere	\$12.35 per 144 pcs	\$182.50 case \$60.35/M	\$170.65 case \$56.43/M	\$160.30 case \$53.01/M	\$151.20 case \$50.00/M
SJ-5303 3024 per case	.44" (11.1mm) .20" (5.0mm)		\$4.80 per 56 pcs	\$170.30 case \$56.32/M	\$159.30 case \$52.68/M	\$149.65 case \$49.49/M	\$141.15 case \$46.68/M
SJ-5306 3024 per case	.375" (9.5mm) .150" (3.8mm)		\$4.55 per 48 pcs	\$186.20 case \$61.57/M	\$174.15 case \$57.59/M	\$163.55 case \$54.08/M	\$154.25 case \$51.01/M
SJ-5312 3024 per case	.50" (12.7mm) .14" (3.5mm)	Cylindrical	\$4.95 per 56 pcs	\$183.15 case \$60.57/M	\$171.30 case \$56.65/M	\$160.90 case \$53.21/M	\$151.70 case \$50.17/M

ACRYLIC SHAPES - CLEAR ONLY

ACRYLIC BALLS

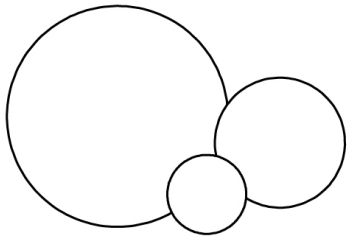

Part No.	Size	25	100	500	1,000
B250	1/4"	\$2.50	\$5.50	\$23.20	\$39.90
B500	1/2"	\$6.95	\$20.90	\$92.40	\$159.00
B750	3/4"	\$15.95	\$52.90	\$226.50	\$412.00
B875	7/8"	\$27.30	\$85.50	\$352.80	\$605.00
B100	1"	\$29.95	\$98.00	\$368.80	\$630.50

ACRYLIC CABOCHONS

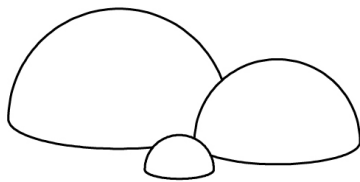

HB375	3/8"	\$3.50	\$9.40	\$37.20	\$63.30
HB500	1/2"	\$4.50	\$13.20	\$53.00	\$90.30
HB750	3/4"	\$12.30	\$39.20	\$166.25	\$293.00
HB100	1"	\$21.75	\$68.00	\$280.40	\$479.10

ACRYLIC CUBES

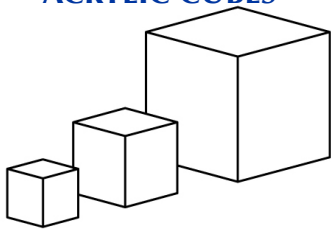

C250	1/4"	\$3.80	\$12.15	\$50.85	\$87.50
C375	3/8"	\$5.35	\$17.20	\$72.05	\$124.10
C500	1/2"	\$6.20	\$20.05	\$84.15	\$145.20
C625	5/8"	\$9.50	\$30.70	\$128.90	\$208.60
C750	3/4"	\$15.60	\$50.20	\$210.60	\$340.30
C100	1"	\$27.80	\$89.55	\$375.75	\$607.50

ACRYLIC DISCS

1/8" Thick

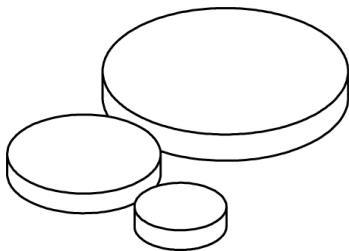

D500	1/2"	\$7.90	\$25.10	\$104.10	\$178.00
D750	3/4"	\$8.80	\$27.95	\$116.05	\$198.60
D1000	1"	\$9.85	\$31.30	\$130.05	\$222.70
D1250	1-1/4"	\$15.25	\$48.40	\$200.85	\$343.50
D1500	1-1/2"	\$19.95	\$63.30	\$262.60	\$408.00
D1750	1-3/4"	\$25.75	\$81.75	\$339.05	\$526.60
D2000	2"	\$29.90	\$94.95	\$393.95	\$612.00
D2500	2-1/2"	\$35.40	\$112.35	\$466.05	\$724.00

Cracked Display Ice - Sold per pound		1-5 lbs	6-15 lbs	16-25 lbs	26 lbs - Up
Acrylic 4000-AC	Color: Clear Only	\$12.90	\$11.80	\$10.90	\$10.15
Styrene 4000-PS	Color: Clear Only	\$10.90	\$9.85	\$9.00	\$8.75

ADJUSTABLE FIXTURE HARDWARE

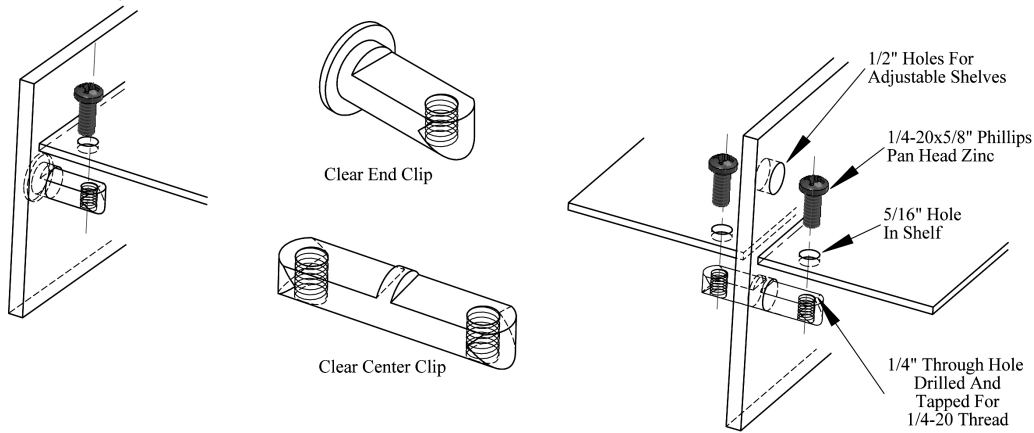

This adjustable fixture hardware was designed to give your displays a clean professional look, while avoiding the hassles of gluing shelves or square stock directly to the display. This system makes it easy to give your customers the versatility of adjustable shelving without jeopardizing strength.

Part No.	Description	Each	50	100	500	1,000	2,500
6944	End Clip W/O screw	79¢	71¢	64¢	59¢	54¢	50¢
6944-1	End Clip with screw	84¢	76¢	69¢	64¢	59¢	54¢

6945	Center Clip W/O screws	\$1.05	95¢	85¢	79¢	73¢	68¢
6945-2	Center Clip with screws	\$1.15	\$1.05	95¢	87¢	81¢	75¢

TURNTABLES CLEAR

T2001 - T2002 - T2003 - T2005

T2004

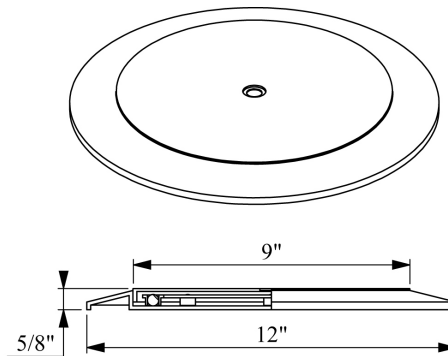
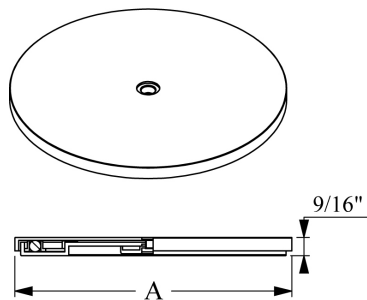

Part No.	Description "A"	Each	50	100	500	1,000
T2001	4 1/4" TurnTable	\$1.15	\$1.10	\$1.00	95¢	90¢
T2002	5 1/2" TurnTable	\$1.85	\$1.75	\$1.65	\$1.60	\$1.45
T2003	9" TurnTable	\$3.95	\$3.60	\$3.35	\$3.10	\$2.92
T2004	12" TurnTable	\$5.60	\$5.10	\$4.85	\$4.45	\$4.20
T2005	12" TurnTable	\$8.65	\$7.85	\$7.50	\$6.95	\$6.50

Also Available In

BLACK or WHITE

GIVE US A CALL OTHER SIZES ALSO AVAILABLE.

T2005 is a Heavy Duty / Double Bearing / 5/8" Thick / Flat TurnTable

NOTE: 12" TurnTables (T2004 & T2005) are manufactured from **PETG** for superior strength

FTM - Fabrication Tools & Materials

Phone: (530) 626-1986 | Fax: (530) 642-2602

GLUE-ON HOOKS & HOLDERS

1/8" Round Hooks

Material: PETG

Part #	Base	Length	Each	25	100	500	1,000	5,000
H001	1/2"	1"	22¢	\$2.89	\$9.50	\$29.60	\$44.90	\$197.00
H002	5/8"	1 1/2"	22¢	\$2.99	\$10.20	\$31.30	\$47.50	\$209.00
H003	5/8"	2"	22¢	\$2.99	\$10.20	\$33.00	\$50.10	\$220.00

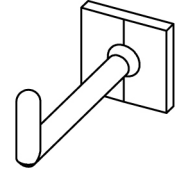

1/4" Flat Hooks

Material: PETG

Part #	Base	Length	Each	25	100	500	1,000	5,000
H004	5/8"	1 1/2"	25¢	\$3.20	\$10.90	\$33.95	\$51.60	\$227.00
H005	5/8"	2"	25¢	\$3.30	\$10.90	\$35.15	\$53.70	\$237.00

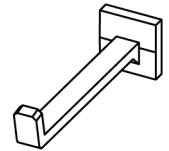

3/8" Flat Hooks

Material: PETG

Part #	Base	Length	Each	25	100	500	1,000	5,000
H006	3/4"	2 1/2"	30¢	\$3.60	\$12.00	\$37.35	\$57.10	\$252.00
H007	3/4"	3"	30¢	\$3.80	\$12.50	\$39.40	\$60.20	\$265.00
H008	5/8"	2"	30¢	\$3.50	\$11.50	\$36.05	\$55.10	\$242.00

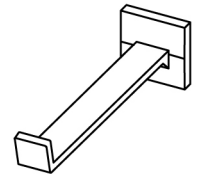

CLEAR HOOK HOLDERS

ADVANTAGES:

- Clear Acrylic.
- You can ship your finished display FLAT.
- LOWER shipping cost.
- Eliminate claims for broken hooks.
- No more unreplaceable broken hooks on displays.
- Customer can change hooks for different requirements.

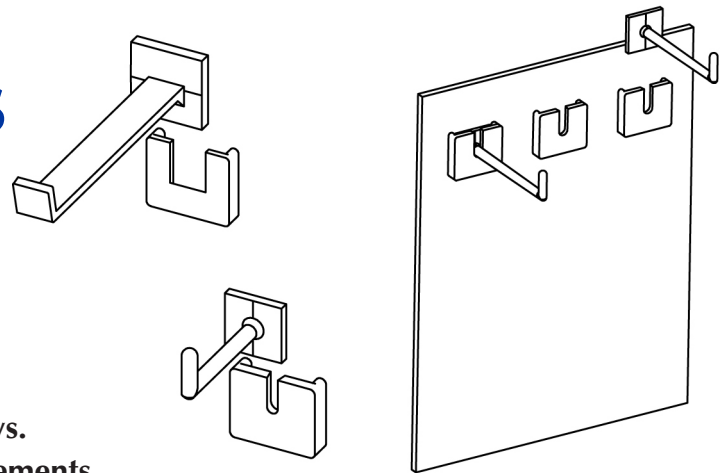

Part #	Fits Hook Number	Each	25	100	500	1,000
H500R	H001	13¢	12¢	10¢	9¢	7¢
H625R	H002 & H003	13¢	12¢	10¢	9¢	7¢
H625F	H004, H005 & H008	13¢	12¢	10¢	9¢	7¢
H750F	H006 & H007	13¢	12¢	10¢	9¢	7¢

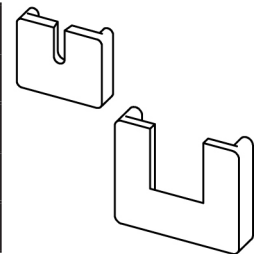

FTM

FABRICATION TOOLS AND MATERIALS, INC.

327 Industrial Dr. Unit 1
Placerville, CA 95667

PRSRT STD
U.S. POSTAGE
PAID
PERMIT #234
Placerville, CA
95667

Adhesives & Applicators

SCIGRIP Solvents.....	20
Solvent Applicators	19

Bumpers

3M Bumpons™	35
BSI Bumpers	35

Display Hardware

Adj. Fixture Hardware	37
Card Pockets (Glue On)	34
Hangers.....	25
Hasps & Catches	24
Handles & Knobs.....	23
Hinges.....	21,22
Hooks and Holders.....	38
Optical Nose Piece.....	26
Suction Cups	27
Turn Tables	37

Drill Bits (Acryl-Point™)

Fractional Sizes.....	14
Lettered Sizes	16
Metric Sizes.....	16
Numbered Sizes	15
Sets	13

Drill Bits (Black & Gold Series)

Fractional Sizes.....	14
Sets	13

Terms and Conditions:

1. Terms are NET 30 DAYS, upon approved credit.
2. 1½% or \$15.00 service charge per month (whichever is greater) will be added to past due accounts with reasonable attorneys fees, collection agency fees, and court costs in the event action for collection must be taken.
3. Accounts reviewed and subject to closure if unpaid balance exceeds 30 days past due.
4. Returned checks will have a \$25.00 service charge added with reasonable attorneys fees, collection agency fees, and court costs in the event of action for collection must be taken.
5. Payments must be in US dollars.
6. Minimum order is \$25.00. Orders under the minimum will be charged a \$10.00 handling fee.
7. All shipments are FOB Placerville, CA. unless otherwise specified.
8. FTM Inc. will not be liable for any loss or damages in excess of the purchase price of our products sold.
9. Prices and specifications are subject to change without notice.
10. A 15% restocking fee shall apply to returned items. Items must be returned within 1 year from date of purchase.
11. Credit Cards (VISA, MASTERCARD and, AMERICAN EXPRESS) accepted on most purchases.
12. Cancelled credit card orders will be charged a 5% cancellation fee.

Router Bits

LMT Onsrud.....	18
Whiteside Machine	17

Saw Blades for Plastics

General Saw.....	6
Tenryu America	7

Hand Tools

Ceramic Scrapers	12
Flap Wheels	11
Metal Scrapers 12	
Scribes	12
Tandem Edge Scraper	12

Heating Equipment

Complete Heating System	1
Free-Standing Strip Heaters	2
Power Controls	3
Silicone Strip Heaters	4
Replacement Parts	4

Layout Programs

Mini-Mizer & Itemizer	7
-----------------------------	---

Literature Holders

Business Card Holders	33
Card Pockets (Glue On)	34
Free-Standing Holders	33
Outdoor Real Estate Boxes.....	34
Wall Mounted Holders	33

Locks

Cam Locks (Metal)	31
Cam Locks (Acrylic).....	32
Pad Locks	32

Panel Saws

Safety Speed Mfg.....	8
-----------------------	---

Plastic Welding

Leister Hot Air Tools	9,10
-----------------------------	------

Polishing

Buffing Wheels, Supplies	29
Cotton Work Gloves	30
Flame Polishing Equip.	11
Flap Wheels	11
Kleenmaster Brillianize.....	28
Micro-Fiber Cloths.....	27
Micro-Filament Wipes	28
Micro-Surface Products	30
Novus Cleaners	28

Shapes (Acrylic)

Balls	36
Cabochoons	36
Cracked Display Ice.....	36
Cubes.....	36
Discs	36

Tapes

Double Coated Tape	30
PTFE / Sealer kit	4

Vacuum Clamping

Vacuum Pumps	5
--------------------	---

General Information

Office Hours: 7:30am to 4:00pm PST Monday - Friday

Tel: (530) 626-1986 Fax: (530) 642-2602 www.123ftm.com e-mail: info@123ftm.com

Mailing Address: P.O. Box 567 El Dorado, CA 95623 USA

Ship To: 327 Industrial Dr. - Unit 1, Placerville, CA 95667 USA